

ELECTRICAL CHARACTERISTICS

Nominal Capacity 14.5Ah
(15mA,+25°C 2V cut off.The capacity restored by the cell varies according to current drain, temperature and cut-off)

Nominal Voltage 3.6V

Max.continuous current 2000mA

Max.Pulse Capability 4000mA

Storage(recommended) Max.30°C
(For more severe conditions,consult Ramway)

Operating Temperature Range - 60°C~+85°C
(Operation at temperature different from ambient may lead to reduced capacity and lower voltage plateau readings)

Weight Approx.110g



SIZE:D

KEY FEATURESAPPLICATION

- High and stable operating voltage
- Low self discharge rate(less than 1% after 1 year of storage at 25°C)
- Long storage life
- Widely operating temperature range
- Stainless steel container(with low magnet)
- Hermetic glass-to-metal sealing
- Non-flammable electrolyte
- CE,SGS recognized,ISO9001 approved
- Utility metering
- Memory back-up
- Alarms and security devices
- Tollgate systems
- Military electronics
- Automotive electronics
- Professional electronics
- GPS tracking
- Real time clock

Note:Information in the document is just for reference.Latest edition of the publication, the right of interpretation subject to RAMWAY.

DISCHARGE CHARACTERISTICS (+25°C)

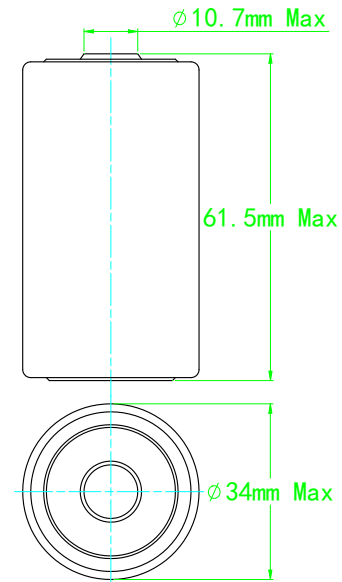
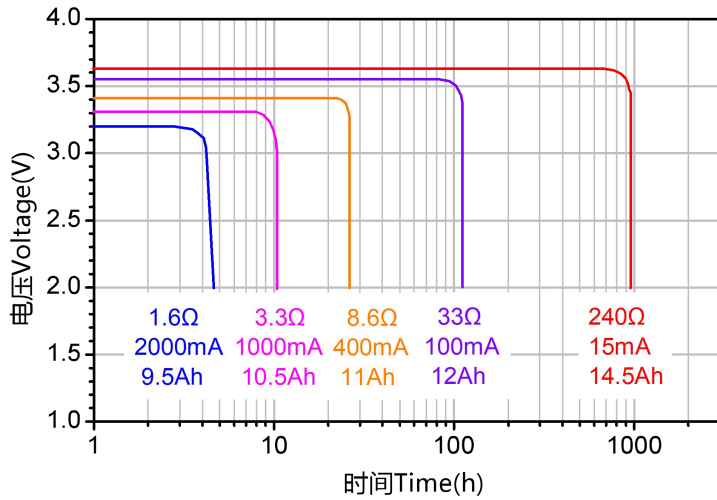

VOLTAGE VERSUS TEMPERATURE

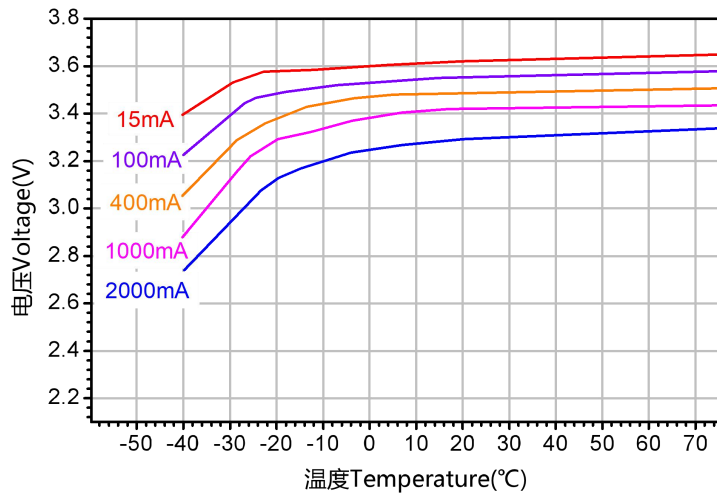

(For different connecting methods consult RAMWAY)

CAPACITY VERSUS CURRENT

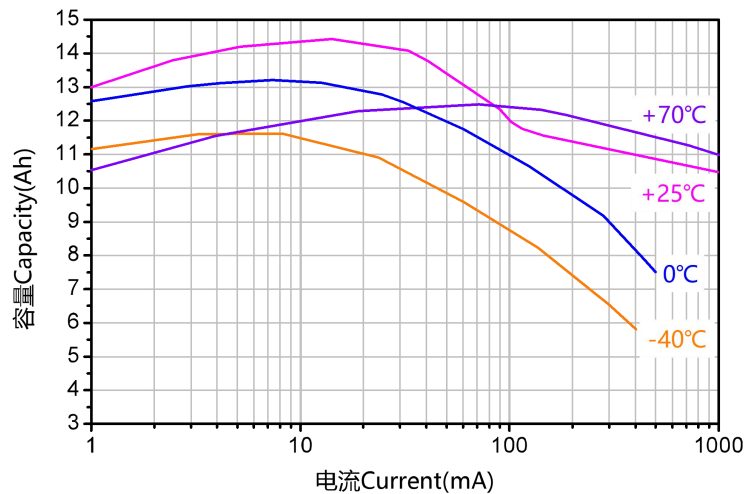

WARNING

- ✦ It is strictly forbidden to have the battery positive and negative short circuit, charging, discharging, heating over 100 °C, remove, anatomy, or may cause explosion, combustion, internal acid leakage.
- ✦ Do not solder directly on the battery, should use wire or nickel sheet by pre spot welded .
- ✦ Can not mixed use with old and new battery or mixed use different kinds battery.
- ✦ Don't assemble the batteries from different manufacturers.
- ✦ Do not use the battery exceed the temperature range.
- ✦ Discharged battery should be buried deeply in the ground.