



**Established**

Taiwan , year 1990

**Main Business**

CviLux Brand & ODM/OEM Business

**Key Products**

Connector, FFC, Wire Harness, Cable Assemblies, PCBA, Electronic Components, 3C Product ... etc.

**Competitive Advantage**

- (1) Listed Company in Taiwan Stock Market (TWSE8103)
- (2) Worldwide Sales Network
- (3) Advance ERP & Customer Service
- (4) Integrated Marketing Service System
- (5) Turnkey Green Product Solution
- (6) International Standard of QC & Certificates

**Factory & Office Location**

Taiwan – Tamsui Plant – Headquarters (CCT)

- China – Dongguan Plant – 1 (CED)
- Dongguan Plant – 2 (DQH)
- Dongguan Plant – 3 (CED2)
- Suzhou Plant (HBC)
- Chongqing Plant (CQC)
- Anhui Plant (AHC)
- Shenzhen Office (CTS)

Lao – Lao Plant (LAO)

USA – USA Office (CUC)

**Sales Agent**

Allsor Technology Corporation (Taiwan)

Allsor (Dongguan) Technology Corporation (China)

**Quality Policy**

Improve Our Product Quality & Operation System  
To Satisfy Our Customer's Demand

**I.P.O.**

TWSE8103 (Taiwan Stock Exchange Corp.)



CviLux Corporation Headquarters, Taiwan

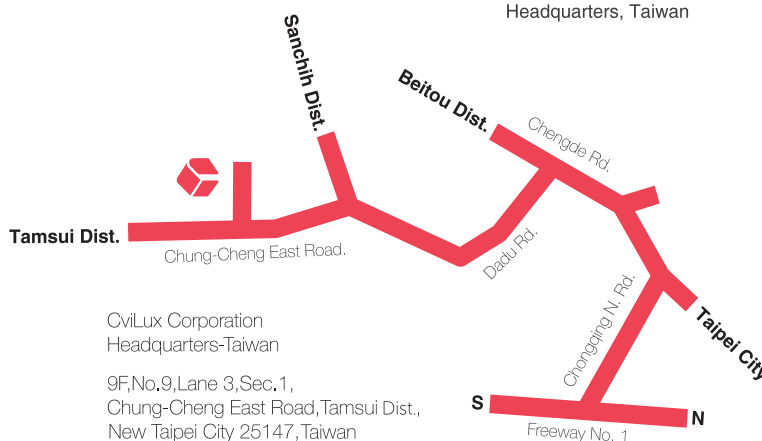

CviLux Electronics (Dongguan) Co., Ltd.



CviLux Technology (Shenzhen) Corporation



CviLux Technology (Chongqing) Corporation



Dongguan Qunhan Electronics Co., Ltd.

## TERMS & CONDITIONS

### Sample Request

Samples will be dispatched out by freight collected courier against prices approved by customers.

### Tape & Reel Request

T/R available, please consult manufacturer for details.

### Quotation Validity

Quoted prices are based on current selling prices and will be valid within 6 months from issued date. CviLux reserves the right to adjust quoted prices any time in response to International raw material costs or simply error correction on typing.

### Export Payment Terms

Standard term is T/T in advance. Payment term extension application to be approved by CviLux individually.

### Minimum Package Quantity

Customer order quantity should meet our minimum package quantity for purpose of inventory control and speeding up for delivery.

### Minimum Order Quantity

To smooth production process, please place orders to meet our MOQ based on different products.

### Delivery Term

**(A)** Air shipment amount over USD 5000/ EURO 4500  
F.C.A. Taiwan/H.K./ Shanghai.

**(B)** Air shipment amount less than USD 5000 / EURO 4500:  
F.C.A. Taiwan/H.K./ Shanghai + handling charge USD 350/  
EURO 310 or EXW without handling charge.

**(C)** Sea shipment amount over USD 12000/ EURO 11000:  
F.O.B. Taiwan/H.K./ Shanghai.

**(D)** Sea shipment amount less than USD 12000/ EURO 11000: F.O.B. Taiwan/H.K./Shanghai + handling charge USD 350/ EURO 310 or EXW without handling charge. CviLux reserves the right to adjust handling charge to reflect actual transportation cost and exchange rate if any necessary.

### Time of Delivery

All delivery dates quoted are estimated, are not guaranteed and do not form a term of contract, while every endeavor will be made to comply with these dates, CviLux shall have no liability for any delay in dispatch or delivery.

### Placing Orders

Please place a formal order by fax, e-mail. Verbal Phone orders will not be accepted or entered into our system. place a formal order by fax, e-mail. Verbal phone orders will not be accepted or entered into our system.

### Orders Cancellation and Changes

Customer's orders' cancellation or changes should be informed in 3 days after orders placing. Any unrecoverable manufacturing cost raised by the cancellation and changes will be charged to the customers.

### Shipping

Special shipping instruction will be followed whenever possible. If no special demand of shipping, we will deliver the shipment to you with the "best way."

### Constant Product Improvement

The products supplied may not be agreed in all details with description and illustrations. Product specifications are subject to constant improvement.

### Guarantee

All "non-customized" parts from CviLux Corporation are unconditionally guaranteed for 30 days from the date of shipment.

### Warranty

CviLux Corporation warrants the materials and workmanship of its products for 80 days from the date of shipment.

### Returned Goods

Any defects or errors for which we are responsible will be promptly rectified. Approval for return of goods must be requested by CviLux. All products returned must have been purchased from CviLux Corporation within 6 months from the date of invoice, and must be packed and shipped in clean and re-saleable condition. Credit for returned goods shall only be allowed by receiving CviLux official credit notes acer above requirements have been met

### Force Majeure

CviLux shall have no liability in respect of failure to deliver or per form or delay in delivering or performing any obligations to the customer, due to any cause of whatsoever nature outside of the reasonable control of the seller including but not limited to causes arising from acts or omissions of the customer.

### Export Control Regulations

Some or All of the goods supplied by CviLux may be subject to export control regulations. Such goods may not be exported by the customer without prior approval of the relevant authorities. It is the responsibility of the customer to obtain such approval. Under no circumstances shall the seller be liable for any loss or damages incurred by the customer as a result of customer's contravention of any export control regulations.





**Wire to Board & Cable Assembly**



**Power Connectors**



**Pin Headers**



**FFC/ FPC Connectors**



**RF Connectors**



**D-SUB Connectors**



**FFC**

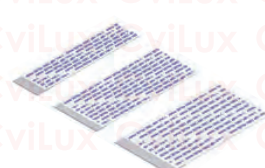

**USB Type C Connectors & Cable**







## Wire to Board & Cable Assembly



## Pin Headers

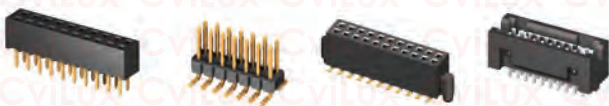

## FFC/ FPC Connectors & FFC



## RF Connectors



## D-SUB & Combo D-SUB



## Telephone Jacks



## USB Type C Connectors & Cable



## Mini PCI-E







## Wire to Board Connectors & Harness Cable



## FFC/FPC Connectors

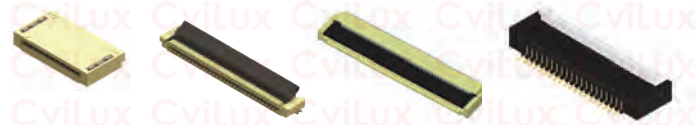

## FFC & LVDS FFC



## Power Connectors



## LED Holder



## USB Type C Connectors & Cable





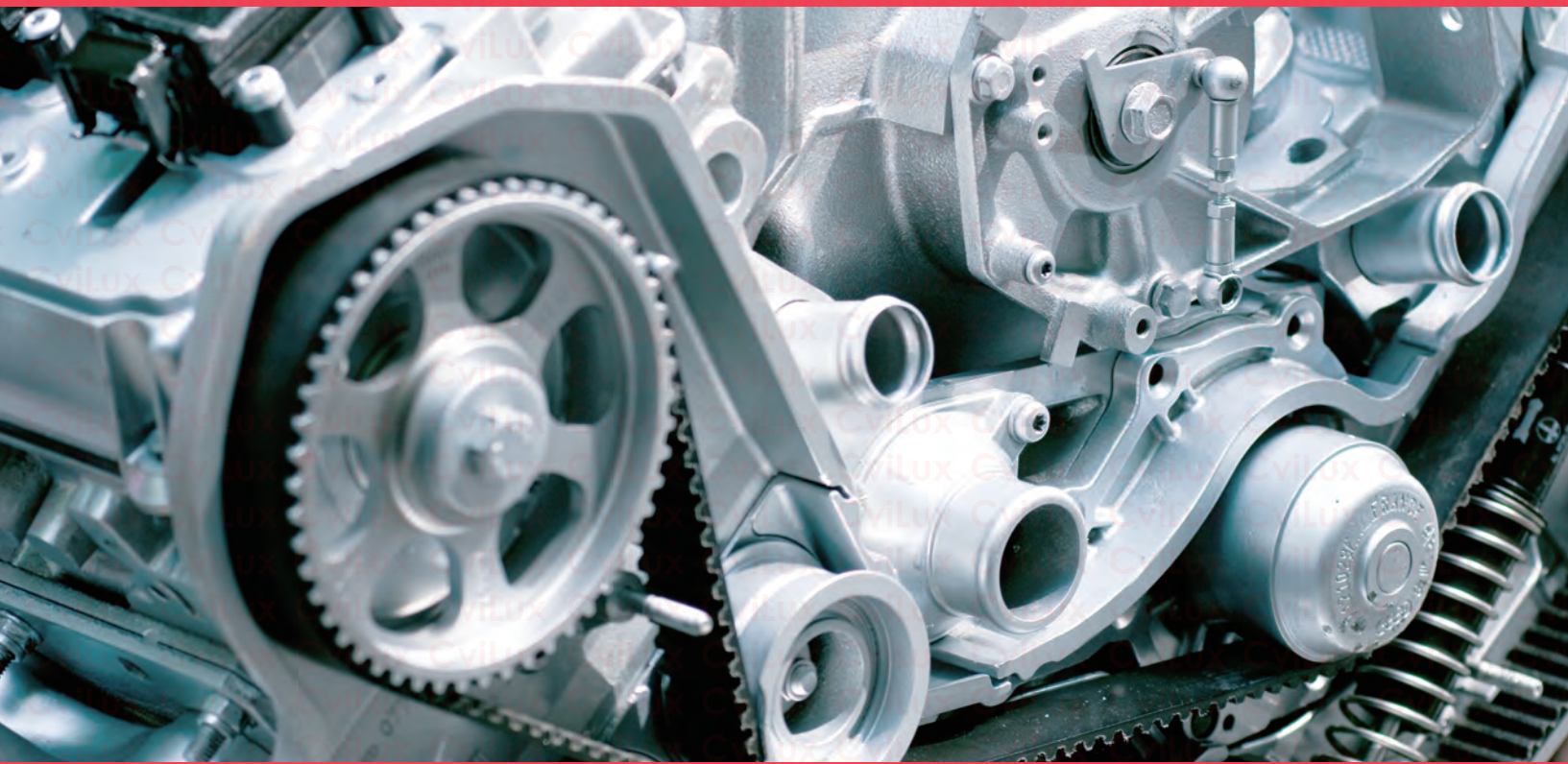

## IDC Connectors & Cable

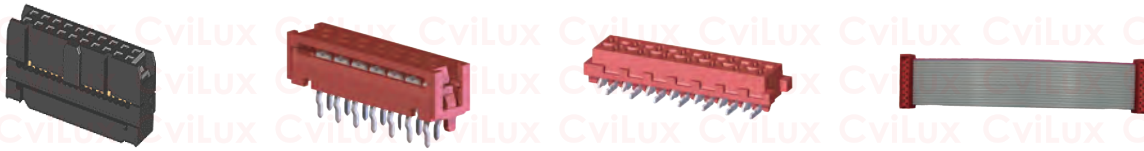

## FFC/FPC Connectors & FFC



## Power Connectors



## Pin Headers

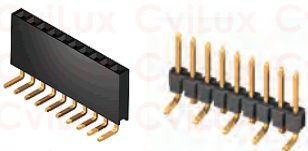

## BTB Connectors



## D-SUB

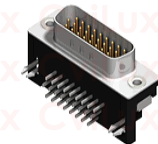

## USB Type C Connectors & Cable



## USB



## IC socket

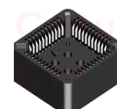

## Jumper





# Laptop Industry

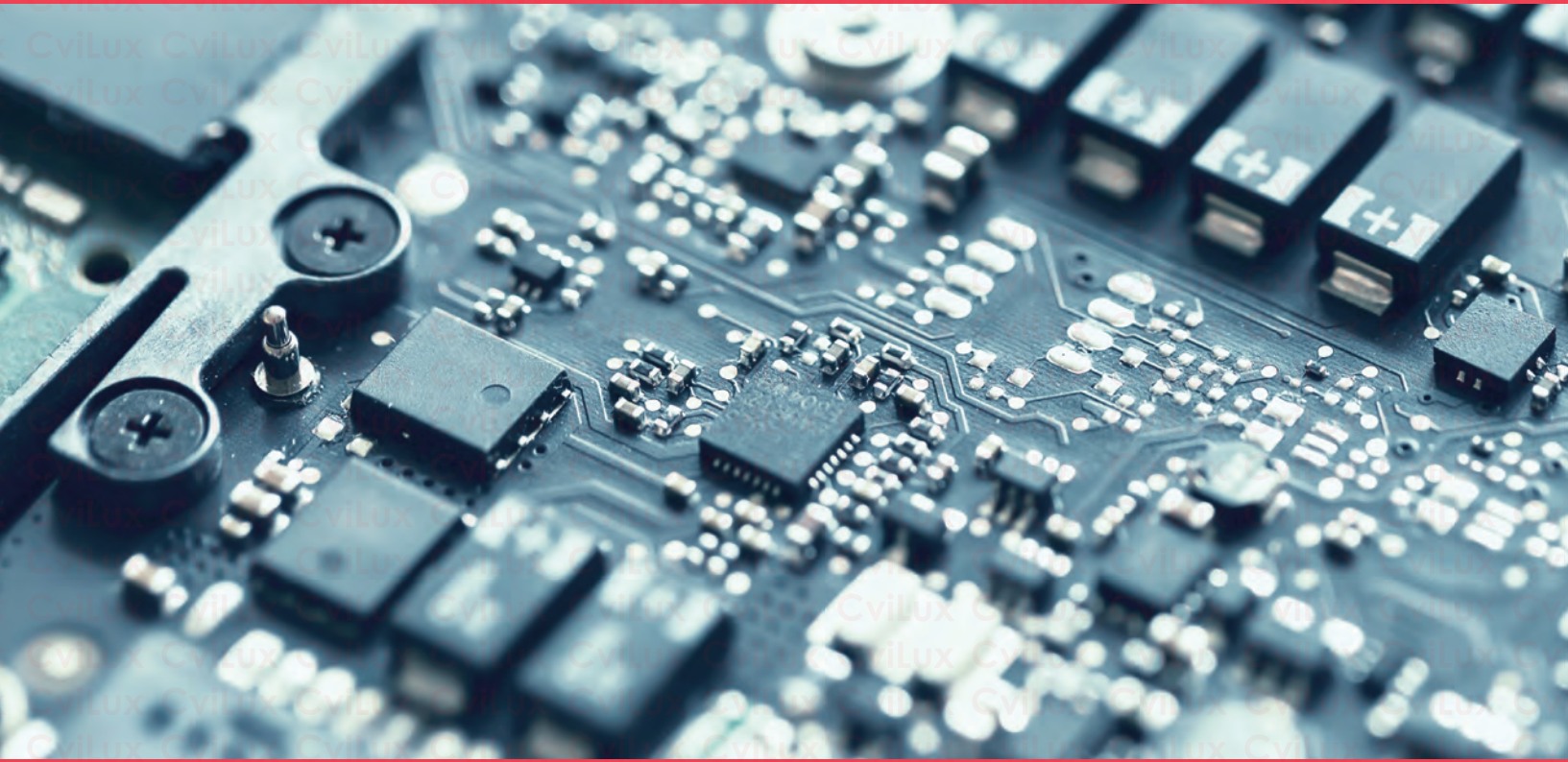

## Wire to Board Connectors

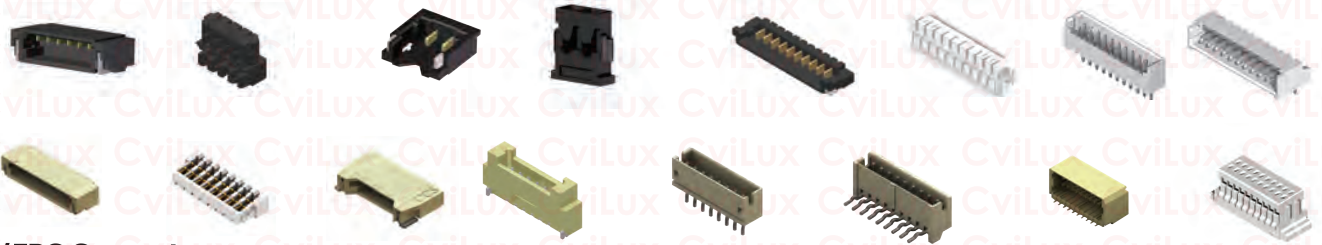

## FFC/FPC Connectors

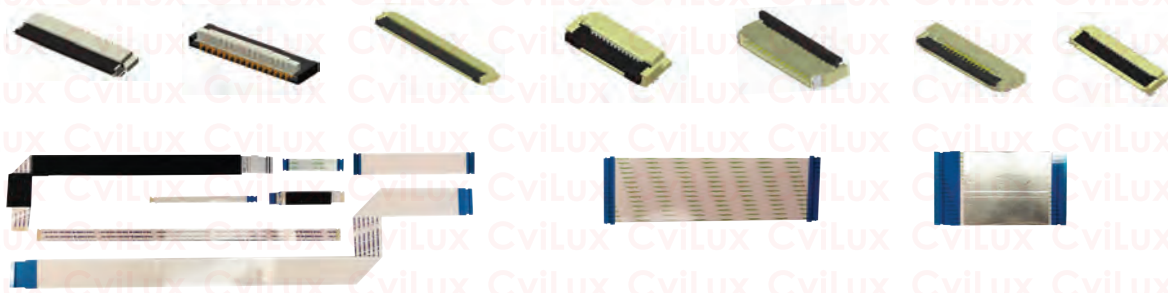

## BTB Connectors



## LVDS Connectors



## USB Type C Connectors



## I/O Connectors







## Wire to Board Connectors



## FFC/FPC Connectors & FFC



## BTB Connectors



## I/O Connectors



## USB Type C Connectors



## USB Type C Cable



# PRODUCT CATEGORY



**FFC / FPC Connectors**



**FFC and LVDS Cables**



**LVDS Connectors**

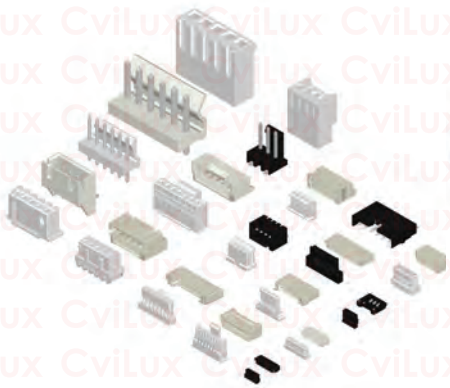

**Wire to Board Connectors**

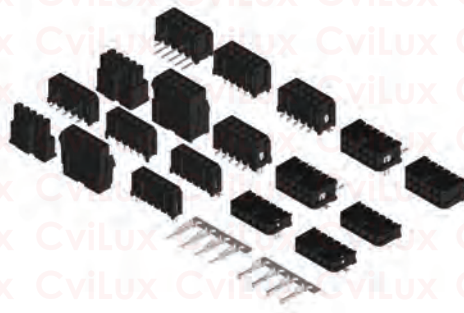

**Power Connectors**

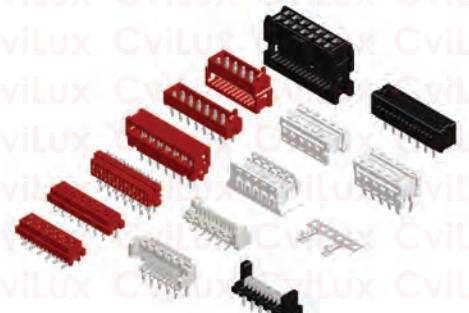

**IDC Connectors**



**Board to Board Connectors**

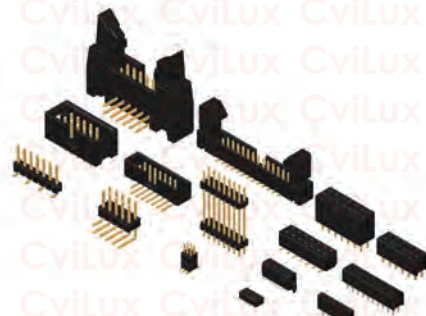

**Pin Headers**



**Socket Connectors**





**D-SUB and  
Combo D-SUB Connectors**



**Modular Jack Connectors**

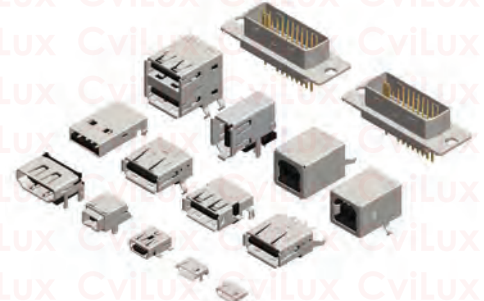

**I/O Connectors**



**USB Type C Connectors**

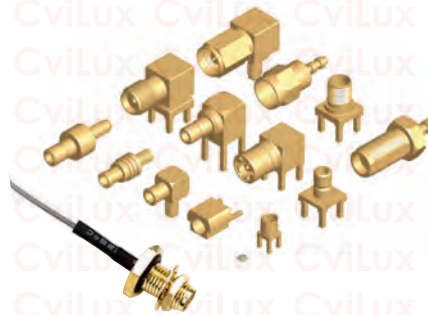

**RF Microwave  
Coaxial Connectors & Cable**



**Pogo Pin Connectors**



**Fiber Optical Connector  
& Cable**



**PCBA**



**Module**

# PRODUCT CATEGORY

## PI High Temperature Film FFC



## Cable with PCBA Assemblies

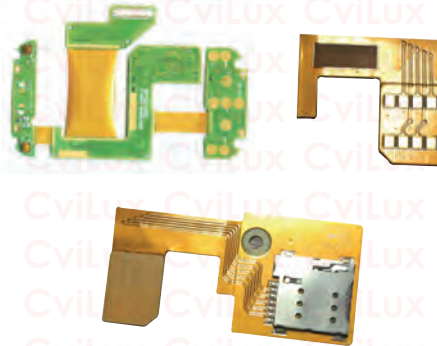

## IDC Cable Assemblies

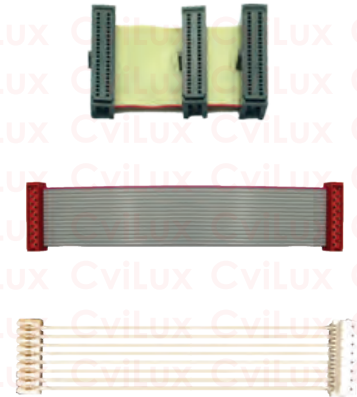

## Type C Cable & Adapter



## Lightning Cable



## HDMI AOC Cable







## STATEMENT OF ENVIRONMENTAL FRIENDLY POLICY

As members of global community, we should all be aware of limited resource consumption and increasing pollution's impact to earth. Our next generation and living animals could live in a dangerous environment without our efforts. Because of this, CviLux Corporation commits to provide environmental friendly products to its clients by using less energy and efficient production. CviLux spirit is to preach such green mind to all the employees and partners who are working closely with us.

Definition:

RoHS Compliant and Lead Free Soldering Process

This letter is released to explain the difference between RoHS compliant and Lead Free Soldering Process. These terms confused R&D designers a lot when they need to select right components and processes for their designs. With this letter, we hope to minimize the confusion and clarify these terms to any one who is interested in this topic.

- RoHS compliant: Indicates raw material of product contained forbidden material within the limitation defined by RoHS directive 2011/65/EU & 2015/863/EU.

- Lead Free Soldering Process: Indicates products themselves can stand specific soldering profile such as J-STD-020C/D or SS-00254.

Currently, there are still no fixed lead free soldering process can be adopted to all kinds of components. For SMT components, the most widely used norms are J-STD-020C/D and SS-00254. As for THT components, JESD22-B106C is the most popular one. CviLux has already set these norms as the standard processes to follow. The details of related soldering temperature of above norms can be found in CviLux product specifications.

Besides, there is still one important concept- It is not a must for RoHS compliant components to adapt Lead Free soldering process. In some cases, it is possible that components are RoHS compliant but not available for lead free soldering process. On the contrary, components available for lead free soldering process are always RoHS compliant. One obvious example is that when cable assemblies can meet RoHS standard, it refers to that the raw materials are environmental friendly only but nothing related to lead free soldering process. PCB components apply the same to the above.

Halogen Free

Halogens are 5 non-metallic elements in group VIIA of the periodic table Fluorine, Chlorine, Bromine, Iodine, Astatine.

Halogens exists, at room temperature, in all three status, Solid ( Iodine, Astatine), Liquid ( Bromine) and Gas ( Fluorine, Chlorine). Currently, only 2 of these 5 elements are normative by IEC, which are Cl and Br.

Why does Halogen Free become new challenges to connector manufacturers? Because the common used connector raw materials like PA66 and PBT are without fire resistance characteristic originally, to strengthen fire resistance characteristic in connector raw materials, Brominated Flame Retardants are used as additive.

However, with more and more emphasis on the importance of Halogen Free products, the use of Brominated Flame Retardants becomes more and more difficult and is restricted by content. To adapt this world wide trend, CviLux has had set its standard of Halogens Free policy according to IEC 61249-2-21 and produce the products since Jan. 2008.

- 900 ppm maximum Cl.
- 900 ppm maximum Br.
- 1500 ppm total Halogens.

Meanwhile, as the research of alternative materials/solutions for better performance plastics is progressing, CviLux will take part in this trend and provide its customers with latest technical support.

## Requirement for install

© Android 7.0 above, iOS 9 above.

### Step 1. iOS/Google Play Key Word Search: CVILUX



### Step 3. General Catalogue



### Step 2. Download E- Catalogue on the shelf

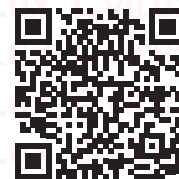

**RoHS Compliant** : RoHS Compliant

: TUV Certified

: UL Certified

: Lead-Free soldering process available

: Halogen-Free

Series	Pitch(mm/inch)	Description	
<b>A. FFC / FPC Connectors</b>			
System CF		Construction of Connector	1
		Connection Combinations of Connector and FFC Cable	2
CF58	0.30(.012")	H=0.90 SMT ZIF FFC/FPC Connectors(Back Lock)	4
CF38	0.30(.012")	H=1.00 SMT ZIF One-Touch FFC/FPC Connectors	5
CF30	0.30(.012")	H=1.25 SMT ZIF One-Touch FFC/FPC Connectors	6
CF86	0.50(.020")	H=0.90 ZIF Side Entry SMT Type FFC/FPC Connectors	7
CF42	0.50(.020")	H=0.96 SMT ZIF One-Touch FFC/FPC Connectors (Back Flip)	8
CF35	0.50(.020")	H=0.96 SMT ZIF One-Touch FFC/FPC Connectors	10
CF87	0.50(.020")	H=0.98 ZIF Side Entry SMT Type FFC/FPC Connectors (Back Flip)	13
CF92	0.50(.020")	H=1.22 SMT ZIF One-Touch FFC/FPC Connectors	14
CF55	0.50(.020")	H=1.25 SMT ZIF One-Touch FFC/FPC Connectors	15
CF88	0.50(.020")	H=1.57 ZIF Side Entry SMT Type FFC/FPC Connectors (Back Flip)	16
CF69	0.50(.020")	H=1.75 SMT LIF One-Touch FFC/FPC Connectors	17
CF39	0.50(.020")	SMT One - Touch FFC/FPC Connectors	18
CF75	0.50(.020")	SMT One-Touch FFC/FPC Connectors	19
CF82	0.50(.020")	H=2.00 SMT ZIF One-Touch FFC/FPC Connectors	20
	1.00(.039")	H=2.00 SMT ZIF One-Touch FFC/FPC Connectors	21
CF76	0.50(.020")	H=2.10 SMT LIF FFC/FPC Connectors	22
CF85	0.50(.020")	H=2.20 SMT ZIF One-Touch FFC/FPC Connectors	23
CF90	0.50(.020")	H=2.20 ZIF FFC/FPC Connectors	24
CF50	0.50(.020")	H=1.46 SMT ZIF One-Touch FFC/FPC Connectors	25
	1.00(.039")	H=1.46 SMT ZIF One-Touch FFC/FPC Connectors	28
CF61	0.50(.020")	H=1.75 SMT ZIF One-Touch FFC/FPC Connectors	32
CF31	0.50(.020")	H=1.95 SMT ZIF One-Touch FFC/FPC Connectors	33
	1.00(.039")	H=1.95 SMT ZIF One-Touch FFC/FPC Connectors	34
CF34	0.50(.020")	H=1.95 SMT ZIF One-Touch FFC/FPC Connectors	36
CF25	0.50(.020")	H=2.20 SMT ZIF One-Touch FFC/FPC Connectors	38
	1.00(.039")	H=2.20 SMT ZIF One-Touch FFC/FPC Connectors	40
CF11	0.50(.020")	H=2.70 SMT ZIF One-Touch FFC/FPC Connectors (Back Flip)	42
	1.00(.039")	H=2.70 SMT ZIF One-Touch FFC/FPC Connectors (Back Flip)	43
CF23	0.50(.020")	H=1.20 SMT ZIF FFC/FPC Connectors	45
	1.00(.039")	H=1.20 SMT ZIF FFC/FPC Connectors	46
CF20	0.50(.020")	H=2.00 SMT ZIF FFC/FPC Connectors	47
	0.50(.020")	H=3.90 SMT ZIF Vertical FFC/FPC Connectors	48
	1.00(.039")	H=2.00 SMT ZIF FFC/FPC Connectors	49
CF27	0.50(.020")	H=1.20 SMT LIF FFC/FPC Connectors	50
	1.00(.039")	H=1.20 SMT LIF FFC/FPC Connectors	51
CF24	0.50(.020")	H=4.20 SMT LIF Vertical FFC/FPC Connectors	52
CF95	0.80(.031")	H=1.50 SMT ZIF FFC/FPC Connectors (Back Flip)	53
CF84	0.80(.031")	H=1.57 SMT ZIF FFC/FPC Connectors (Back Flip)	54
CF32	0.80(.031")	H=1.95 SMT ZIF One-Touch FFC/FPC Connectors	55
CF37	0.80(.031")	H=1.95 SMT ZIF One-Touch FFC/FPC Connectors	56
CF07	1.00(.039")	H=2.60 SMT ZIF FFC/FPC Connectors	57
CF08	1.00(.039")	H=2.60/3.55 SMT LIF & SMT LIF Vertical FFC/FPC Connectors	58
CF09	1.00(.039")	H=2.60/5.50 DIP LIF FFC/FPC Connectors	59



CF73	1.00(.039")	H=3.30 SMT ZIF One-Toach FFC-FPC Connectors	60
CF10	1.00(.039")	H=3.80/5.00 DIP ZIF FFC/FPC Connectors	61
		H=5.20 SMT ZIF FFC/FPC Connectors	62
CF16	1.00(.039")	H=3.80/5.00 DIP LIF FFC/FPC Connectors	63
		H=3.80/5.20 SMT LIF FFC/FPC Connectors	64
CF12	1.25(.049")	H=4.00/6.80 DIP LIF FFC/FPC Connectors	65
<b>B. Flat Flexible Cables &amp; LVDS FFC Cables</b>			
System FFC	Introduction		66
		Features & Applications & Connections	67
		Ordering Code & Terminal Types table	68
		Shape, Construction and Dimensions	69
		Feature & Caution	70
		Performance	71
CFF / CFE		Flat Flexible Cable Assemblies - LVDS FFC Cable	72
FFCA	2.54(.100")	Flat Flexible Cable Assemblies	73
<b>C. LVDS Connectors</b>			
CVS1	0.50(.020")	LVDS H=3.70 Socket Connectors for TV	74
CVS3	0.50(.020")	LVDS M/H=2.00 Socket Connectors for Notebook	75
CVS5	0.50(.020")	LVDS M/H=4.00 Socket Connectors for Notebook	76
CVSC	1.00(.039")	LVDS H=2.35 Socket Connectors for TV/Monitor	77
CVS7	0.50(.020")	LVDS M/H=1.05 Socket Connectors	79
<b>D. Wire to Board Connectors</b>			
System CI		Connection Combination of Wire to Board Connectors	80
CI20	0.60(.024")	Wire to Board Connectors Housing & SMT Headers	81
CI18	0.80(.031")	Wire to Board Connectors Housing & SMT Headers	82
CI11	1.00(.039")	Single Row Wire to Board Connectors Housing & Terminal	83
		Single Row Wire to Board Connectors SMT Headers	84
		Dual Row Wire to Board Connectors Housing & Terminal	85
		Dual Row Wire to Board Connectors SMT Headers	86
CI16	1.00(.039")	Wire to Board Connectors Housing & Terminal	87
		Wire to Board Connectors SMT Headers	88
CI14	1.00(.039")	Wire to Board Connectors Housing & Terminal	89
		Wire to Board Connectors SMT Side Entry Headers	90
		Wire to Board Connectors Housing & SMT Side/Top Entry Headers	91
CI63	1.20(.048")	Wire to Board Connectors Housing & Terminal & SMT Headers	94
	1.20(.048")	Wire to Board SMT Headers	95
CI40	1.25(.049")	Wire to Board Housing & Terminal	96
		Wire to Board SMT Headers	97
CI42	1.25(.049")	Wire to Board Housing & Terminal	98
	1.25(.049")	Wire to Board SMT Header	99
CI43	1.25(.049")	Wire to Board Connectors Housing & Terminal & SMT Headers	100
CI44	1.25(.049")	Wire to Board Connectors Housing & Terminal	101
		Wire to Board Connectors DIP Headers	102
		Wire to Board Connectors SMT Headers	103
CI45	1.25(.049")	Wire to Board Connectors Housing & SMT Headers	104
CI46	1.25(.049")	Wire to Board Connectors Housing & Terminal	105
		Wire to Board Connectors SMT Headers	106
CIDL	1.25(.049")	Wire to Board Connectors	107
CI15	1.50(.059")	Wire to Board Connectors Housing & Terminal	108
		Wire to Board Connectors DIP & SMT Headers	109

		Wire to Board Latch Type Housing & SMT Headers	110
CI19	1.50(.059")	Wire to Board Connectors Housing & Terminal	112
		Wire to Board Connectors SMT Headers	113
CI87	1.50(.059")	Wire to Board Connectors Housing & Terminal & SMT Headers	114
CIDW	1.50(.059")	Single Row Wire to Board Housing & Terminal	115
		Wire to Board Connectors SMT Headers	116
CIEJ	1.50(.059")	Single Row Wire to Board Housing & Terminal	117
		Single Row Wire to Board SMT Headers	118
CI07	1.80(.071")	Wire to Board Connectors Housing & Terminal	119
		Wire to Board Connectors SMT Headers	120
CI01	2.00(.079")	Single Row Wire to Board IDC Housing & Terminal	121
		Single Row Wire to Board Connectors DIP & SMT Headers	123
		Single Row Wire to Board Latch Type Housing & SMT Header	124
		Dual Row Wire to Board Connectors Housing & Terminal	126
		Dual Row Wire to Board Connectors DIP Headers	127
CI02	2.00(.079")	Board In Connectors	128
CI06	2.00(.079")	Wire to Board Connectors Housing & Terminal	129
		Wire to Board Connectors DIP & SMT Headers	130
CI08	2.00(.079")	Wire to Board Connectors SMT & DIP Headers	131
CI10	2.00(.079")	Wire to Board Connectors SMT Headers	132
CIDX	2.00(.079")	Single Row Wire to Board Housing & Terminal	135
		Wire to Board Connectors SMT Headers	136
CIDY	2.00(.079")	Single Row Wire to Board Housing & Terminal	137
		Wire to Board Connectors DIP Headers	138
CID9	2.00(.079")	Single Row Wire to Board Housing & Terminal	139
		Single Row Wire to Board SMT Headers	140
CIEG	2.00(.079")	Single Row Wire to Board Housing & Terminal	141
CIE4	2.00(.079")	Daul Row Wire to Board to Board DIP Headers	143
CI21	2.50(.098")	Wire to Board Connectors Housing & Terminal	144
		Wire to Board Connectors DIP Headers	145
CI22	2.50(.098")	Wire to Board IDC Connectors Housing & Terminal	146
		Wire to Board IDC Connectors Housing & IDC Cable	147
		Wire to Board IDC Connectors Connectors DIP Header	148
CI23	2.50(.098")	Wire to Board Connectors Housing & Terminal	149
		Wire to Board Connectors DIP Headers	150
CI25	2.50(.098")	Wire to Board Connectors Housing & Terminal	151
		Wire to Board Connectors DIP Headers	152
CI26	2.50(.098")	Board In Connectors	153
CI27	2.50(.098")	Board In Connectors	154
CI30	2.50(.098")	Wire to Board Connectors DIP Header	155
CI60	2.50(.098")	Wire to Board Connectors DIP Header & Housing & Terminal	156
CIL4	2.50(.098")	Wire to Board Connectors SMT Headers	157
CI31	2.54(.100")	Wire to Board Connectors Housing & Terminal	158
		Wire to Board Connectors DIP Headers	159
CI32	2.54(.100")	Wire to Board Connectors Housing & Terminal	160
CI34	2.54(.100")	Dual Row Wire to Board Connectors Housing	161
CI33	2.54(.100")	Single Row Wire to Board Connectors Housing	162
		Single Row Wire to Board Connectors DIP Headers	163
		Dual Row Wire to Board Connectors Connectors	164
		Dual Row Wire to Board Connectors	165



CI35	2.54(.100")	Wire to Board Connectors	166
CI39	2.54(.100")	Wire to Board Connectors SMT Headers	167
CI83	2.54(.100")	Friction Lock Breakaway Headers	168
CID2	2.54(.100")	IDC type Connectors	169
CID7	2.54(.100")	Wire to Board Housing/Terminal/Straight Headers	170
CIL1	3.50(.138")	Board to Board connectors	171
CI51	3.96(.156")	Wire to Board Connectors Housing & Terminal	173
		Wire to Board Connectors DIP Headers	174
CI52	3.96(.156")	Wire to Board Connectors Housing & Terminal	175
		Wire to Board Connectors DIP Headers	176
	7.92(.312")	Wire to Board Connectors DIP Headers	177
CI82	3.96(.156")	Friction Lock Breakaway Headers	178
CI77 /CI78	3.96(.156")	Breakaway Pin Headers	179
CID1	4.00(.157")	Wire to Board Connectors SMT Header	180
CI55	5.08(.200")	Wire to Board Connectors	181
<b>E. Power Connectors</b>			
System CP		Connection Combination of Power Connectors	182
CP75	1.50(.059)	Board to Board Receptacle Connector	183
		Board to Board Plug Connector	184
CP14	1.50(.059")	Single Row Side Entry SMT Headers	185
CP15	1.50(.059")	SMT Headers	186
CPB1		Waterproof Connectors	189
CPB2	2.00(.079")	Waterproof Connectors	190
CP06	2.50(.098")	Receptacle Connectors	193
	2.50(.098")	Plug Connectors	194
CP25	2.50(.098")	Receptacle Connectors	195
CP35	3.00(.118")	Single Row Housing Connectors	196
		Single Row Board Mount Headers	197
		Single Row Side Entry SMT Headers	198
		Single Row Top Entry SMT Headers	200
		Dual Row Receptacle Connectors	201
		Dual Row Plug Connectors	202
		Dual Row Board Mount Headers	203
		Dual Row Side Entry SMT Headers	204
		Dual Row Top Entry SMT Headers	206
CP-01	4.20(.165")	Power Connectors	207
CP-011	4.20(.165")	Receptacle Connectors	208
		Blind Mating Panel Mount Receptacle Connectors	209
		Receptacle Board Mount Connectors	210
		Assembly Power Connectors	211
CP-012	4.20(.165")	Plug Connectors	212
CP-013	4.20(.165")	Straight DIP Solder Headers	213
CP-014	4.20(.165")	Right Angle DIP Solder Headers	216
CP32	5.08(.200")	Power Connectors	219
CP33	5.08(.200")	IDC & Board Mount Receptacle Power Connectors	220
CP60	5.70(.224")	Dual Row Receptacle & Header	221
CP08	6.35(.250")	Single Row Power Connector	223
<b>F. IDC Connectors</b>			
System CA		Connection Combination of IDC Connectors	227
CA30	1.27(.050")	Male IDC & DIP Type Connectors	228

	1.27(.050")	Male IDC SMT Type Connectors	229
CA31	1.27(.050")	Flat Cable - IDC DIP Plugs	230
CA30&CA31		Flat Cable Assemblies	231
CA32	1.27(.050")	Female DIP Type Connectors	232
	1.27(.050")	Female SMT Type Connectors	233
CA33	1.27(.050")	IDC & Crimping Type Connectors	234
CM19		Pull-off tongs for CA33	235
CA34	1.27(.050")	Flat Cable - IDC DIP Plugs	236
CA35	1.27(.050")	Male DIP Type Connectors	237
	1.27(.050")	Male SMT Type Connectors	238
	1.27(.050")	Female DIP Type Connectors	239
CW03	1.27(.050")	Flat Ribbon Cable	240
CA11	2.00(.079")	Center Spacing Flat Cable - IDC Sockets	241
CA21	2.54(.100")	Center Spacing Flat Cable - IDC Sockets	242
CA23	2.54(.100")	Center Spacing Flat Cable - IDC DIP Plugs	243
<b>G. Board To Board Connectors</b>			
System CB		Connection Combination of Board To Board Connectors	244
		Board To Board Connectors Selection Index	245
CBRH	0.40(.016")	Board to Board Connectors	248
CBRQ	0.40(.016")	Board to Board Connectors	249
CBRB	0.50(.020")	Board To Board Connectors	250
CBRC	0.50(.020")	Board To Board Connectors	252
CBRE	0.50(.020")	Board To Board Connectors	254
CBRD	0.80(.031")	Board To Board Connectors	256
CBC3	0.80(.031")	Dual Row Female Headers	258
CB03	1.00(.039")	SMT Type Single Row Pin Headers	259
CB12	1.00(.039")	Dual Row Female Headers	259
CB01	1.27(.050")	Single Row Female Headers	260
CB50	1.27(.050")	Dual Row Female Headers	261
CBC1	1.27(.050")	Dual Row Female Headers	262
CB22	2.00(.079")	Single Row Female Headers	264
CB74	2.00(.079")	Dual Row Female Headers	265
CB76	2.00(.079")	Dual Row Female Headers	266
CB33	2.54(.100")	Single Row Dual Entry Female Headers	267
CB37	2.54(.100")	Single Row Female Headers	267
CB39	2.54(.100")	Single Row Female Headers	268
CB41	2.54(.100")	Dual Row Female Headers	269
CB83	2.54(.100")	Dual Row Female Headers	270
CB85	2.54(.100")	Dual Row Female Headers	270
CB96	2.54(.100")	Dual Row Elevated Female Headers	271
CB91	2.54(.100")	Dual Row Female Headers	272
CB94	2.54(.100")	Dual Row Female Headers	273
CB97	2.54(.100")	Dual Row Side Entry Female Headers	274
CBA7	2.00(.079")	Dual Row Female Headers	274
CGB1		Pogo Pin Connectors	275
<b>H. Pin Header Connectors</b>			
CHC3	0.80(.031")	Dual Row SMT Pin Headers	277
CH07	1.00(.039")	Single Row Board Mount Connectors	278
CH16	1.00(.039")	Dual Row Pin Headers	278
CH01	1.27(.050")	Single Row Pin Headers	279



CH02	1.27(.050")	Single Row Pin Headers	280
CH03	1.27(.050")	Single Row Dual Bodies Pin Headers	281
CH06	1.27(.050")	Straight SMT Dual Row Shrouded Headers	282
CH51	1.27(.050")	Dual Row Pin Headers	283
CH52	1.27(.050")	Dual Row Pin Headers	285
CH57	1.27(.050")	Dual Row Dual Bodies Pin Headers	287
CHC2	1.27(.050")	Dual Row Pin Headers	288
CH60	1.27*1.27mm	Right Angle Dual row board mount pin header	291
CH11	2.00(.079")	Single Row SMT Pin Headers	292
CH21	2.00(.079")	Single Row Dual Bodies Pin Headers	294
CH70	2.00(.079")	Straight SMT Dual Row Shrouded Headers	295
CH71	2.00(.079")	Dual Row SMT Pin Headers	295
	2.00(.079")	Dual Row Pin Headers	296
CH72	2.00(.079")	Dual Row Pin Headers	297
CH74	2.00(.079")	Dual Row Pin Headers	298
CH75	2.00(.079")	Dual Row Dual Bodies Pin Headers	299
CH79	2.00(.079")	Dual Row Pin Headers	300
CH34	2.54(.100")	Single Row Dual Bodies Pin Headers	302
CH31	2.54(.100")	Single Row Pin Headers	303
CH81	2.54(.100")	Dual Row SMT & DIP Pin Headers	305
CH85	2.54(.100")	Dual Row Dual Bodies Pin Headers	306
CH87	2.54(.100")	Box Headers	307
CH88	2.54(.100")	Shrouded Box Headers	308
<b>I. Sockets</b>			
CS76	0.50(.020")	NGFF Connectors	309
CS59	0.80(.031")	Mini PCI 4.0H/2.1H 52pin Connectors	310
CS21	1.27(.050")	DIP PLCC Chip Carrier Socket	311
CS22	1.27(.050")	SMT PLCC Chip Carrier Socket	313
CS78	1.27(.050")	Board to Board Right Angle DIP Connector	314
CS01	2.54(.100")	Dual Row Multiple Shunts	315
CS07	2.54(.100")	DIP Socket - Machined contacts	316
CS09	2.54(.100")	Single in Line Adapter Strip	317
CS10	2.54(.100")	Single in Line SIP Socket	317
CS74		PCI Express Edge Card Connector	318
CSM1		H=3.3mm/1.5mm Dual Type SIM Card Connectors	319
CSM2		Micro SIM Card Connectors	320
<b>J. D-SUB Connectors</b>			
		D-Sub Shell Size & Printed Circuits Board Hole Patterns	321
		High density D-Sub Straight / Right Angle DIP solder PCB hole patterns	322
		D-Sub Accessories & PCB Mounting Options	323
CD01		High Density Solder D-Sub	324
CD03		High Density Straight DIP Solder D-Sub	325
CD05		High Density Right Angle DIP Solder D-Sub	326
CD51		Solder D-Sub	327
CD52		Crimp Clip D-Sub & Terminal	328
CD53		Straight DIP Solder D-Sub	330
CD61		8.10mm Footprint Right Angle DIP Solder D-Sub	331
CD62		8.10mm Footprint EMI Right Angle DIP Solder D-Sub	332
CD91		Flat Cable - IDC D-Sub	333
CD81		Stacked Right Angle DIP Solder D-Sub	334

CD71	Machined Contact Solder Cup D-Sub	336
CD72	Machined Contact Straight DIP Solder D-Sub	338
CD73	8.10mm Footprint Right Angle DIP solder D-Sub	340
COMBO D-SUB	Combo D-sub Technical Specifications	342
	Contact Arrangements/ Mounting Style options	343
	Coaxial Contact for Combination D-Sub	344
	High Power Contact for Combination D-Sub	345
	Combination D-Sub Housing	347
	Coaxial Straight DIP Combination D-Sub	350
	Coaxial Right Angle DIP Combination D-Sub	353
	20A High Power Straight DIP Solder Combination D-Sub	356
	40A High Power Straight DIP Solder Combination D-Sub	359
	20A High Power Right Angle DIP Solder Combination D-Sub	362
40A High Power Right Angle DIP Solder Combination D-Sub	365	
<b>K. Telephone / Modular Jack Connectors</b>		
CJ04	Board Mount Telephone Jacks	368
CJ07	Board Mount Telephone Jacks	369
CJ36	Board Mount Telephone Jacks	369
CJ31	Board Mount Telephone Jacks	370
CJ46	Board Mount Telephone Jacks	372
CJ47	Board Mount Telephone Jacks	372
CJ58	Board Mount Telephone Jacks	372
CJ48	Board Mount Telephone Jacks	373
CJ59	Board Mount Telephone Jacks	374
CJ91	Board Mount Telephone Jacks	375
CJ97	Board Mount Telephone Jacks	376
CJP1	Telephone Modular Plugs	378
CJP2	Telephone Modular Plugs	379
CJB1	Telephone Modular Jack RJ45	380
CJCJ	Telephone Modular Jack RJ45	381
<b>L. I/O Connectors</b>		
CU01	USB 2.0 Type-A Board Mount Receptacle and SMT Plug Connectors	382
	USB 2.0 Type-A Receptacle Connectors	383
CU02	USB 2.0 Type-B Receptacle Connectors	384
CU04	Mini USB2.0 5 Circuits Receptacle SMT/DIP Connectors	385
CU09	Micro USB 2.0 Connectors	386
CU05	IEEE 1394 Shielded I/O Receptacle Connectors	387
CU11	HDMI Receptacle Connectors	388
USB-C	USB TYPE C Technical Specifications	389
CU30	USB3.1 Tpye C Plug SMT Type Connectors	391
CU31	USB Tpye C Socket SMT Type Connectors	398
CU32	USB2.0 Tpye C Female SMT Type Connector	400
CU33	USB2.0 Tpye C Female Vertical Type Connectors	411
	USB2.0 Tpye C Plug SMT Type Connectors	414
CU34	USB2.0 Tpye C SMT Type Connectors	415
CU35	USB2.0 Type C Female Connectors	416
CU39	USB2.0 Type C Female Connectors	417
<b>M. RF / Microwave Coaxial Connectors</b>		
CRA	Micro Coaxial Connectors & Cable	420



CU01 Series USB2.0 Type-A Board Mount Receptacle and SMT Plug Connectors

- High durability and long cycle life
- Designed to meet the USB 2.0 specifications

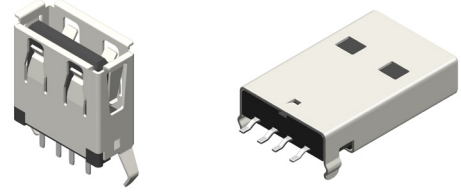

RoHS Compliant

P/N CU01S\*V\*S00

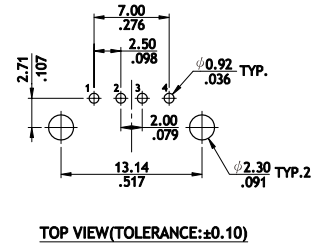
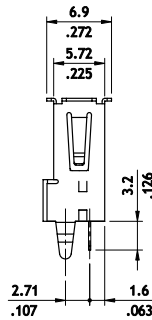
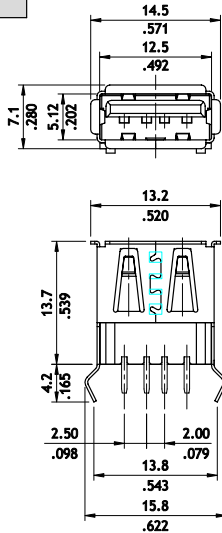

P/N CU01P\*H\*00A

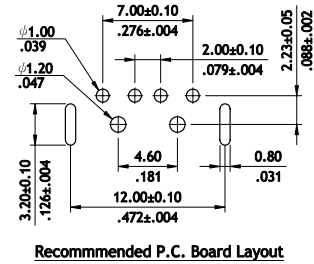
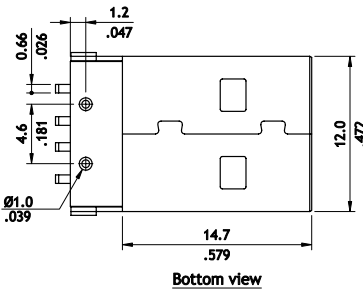
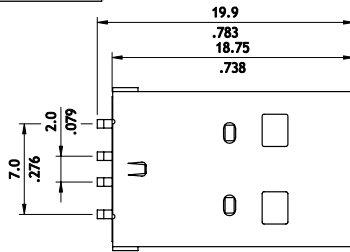

Ordering Code

① ② ③ ④ ⑤ ⑥ ⑦  
**C U 0 1 S A V 0 S 0 0**

- ① Series No.
- ② S = Socket
- ③ Plating Code :  
 A = Selective Gold flash over Nickel  
 C = Selective 30µ" Gold flash over Nickel
- ④ V= Straight DIP
- ⑤ Insulator Color : 1= Black , 0 = White
- ⑥ S = Single port
- ⑦ Options: 00 = Standard

① ② ③ ④ ⑤ ⑥  
**C U 0 1 P A H 1 0 0 A**

- ① Series No.
- ② P= Plug
- ③ A = Selective Gold flash over Nickel  
 C = Selective 30µ" Gold flash over Nickel
- ④ H= Right Angle
- ⑤ Insulator Color : 1 = Black , 0 = White
- ⑥ Options: 00A = Standard

**CU01 Series USB2.0 Type-A Board Mount Receptacle Connectors**

- ⊙ High durability and long cycle life
- ⊙ Designed to meet the USB 2.0 specifications

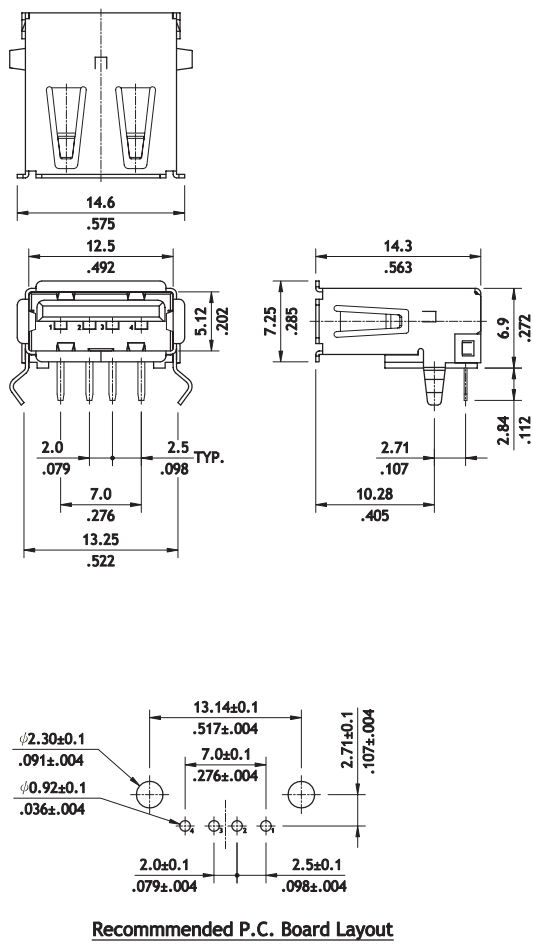
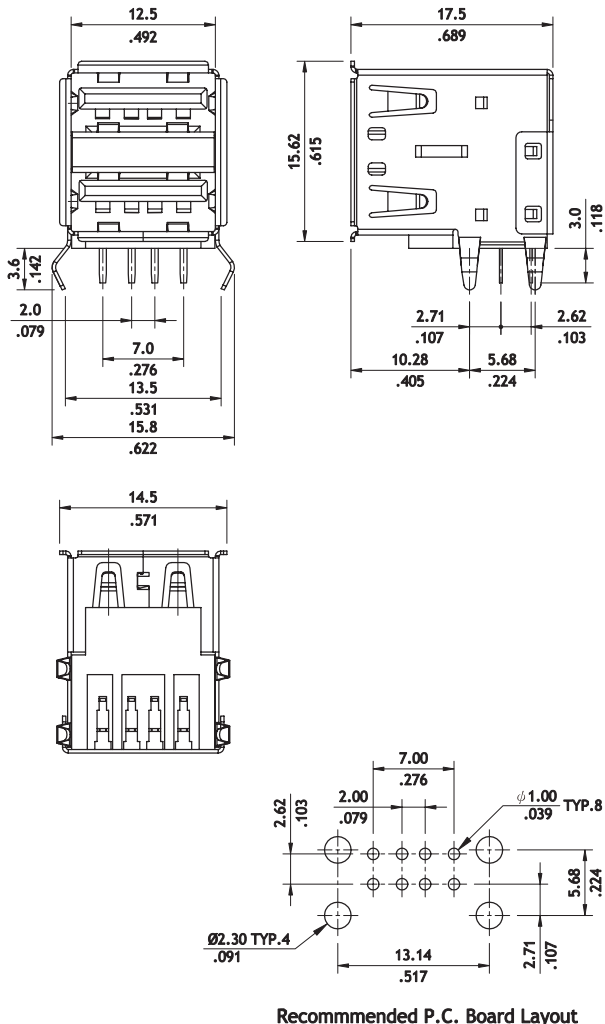
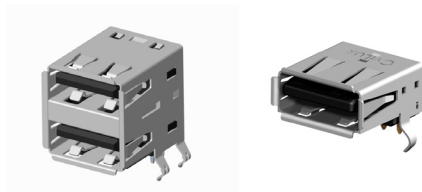

Ordering Code						
①	②	③	④	⑤	⑥	⑦
<b>C</b>	<b>U01</b>	<b>S</b>	<b>A</b>	<b>H</b>	<b>1</b>	<b>D</b>
<b>0</b>	<b>C</b>					
① Series No.	② S = Socket	③ Plating Code :				
	A = Selective Gold flash over Nickel	C = Selective 30µ" Gold flash over Nickel				
④ H= Right Angle	⑤ Insulator Color : 1= Black	⑥ D = Dual port				
⑦ Options: 0C = Without Spring Tab						

Ordering Code						
①	②	③	④	⑤	⑥	⑦
<b>C</b>	<b>U01</b>	<b>S</b>	<b>A</b>	<b>H</b>	<b>1</b>	<b>S</b>
<b>0</b>	<b>0</b>					
① Series No.	② S = Socket	③ A = Selective Gold flash over Nickel				
	C = Selective 30µ" Gold flash over Nickel					
④ H= Right Angle	⑤ Insulator Color : 1 = Black , 0 = White	⑥ S = Single port				
⑦ Options: 00 = Standard						



CU02 Series USB2.0 Type-B Board Mount Receptacle Connectors

- ① 4-position shielded receptacle connector
- ① High durability and long cycle life
- ① Designed to meet the USB 2.0 specifications
- ① USB 2.0 Approved Test ID: 60000738

RoHS Compliant



P/N CU02S\*V\*00\*

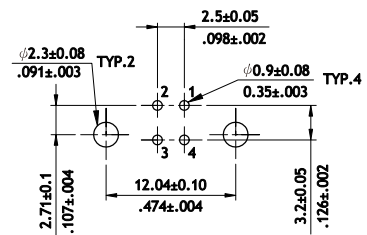
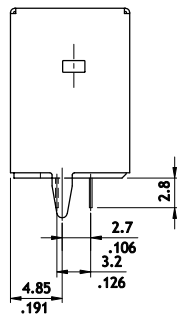
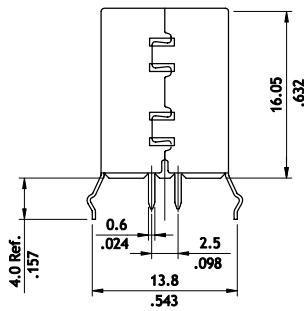
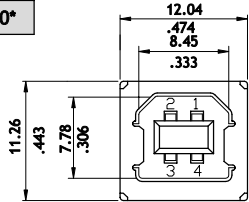

Recommended PCB Layout

P/N CU02S\*H\*000

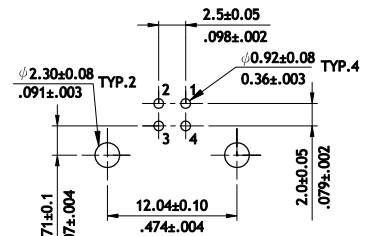
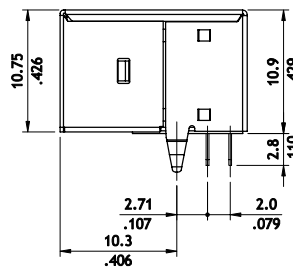
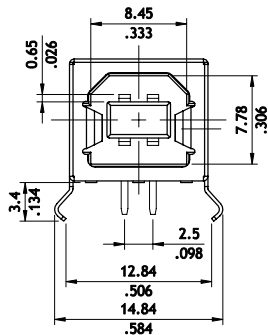
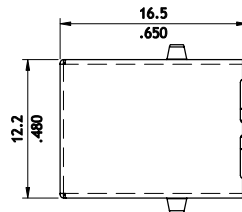

Recommended PCB Layout

Ordering Code

① ② ③ ④ ⑤ ⑥  
**CU02 S A H 0 000**

- ① Series No.
- ② S = Socket
- ③ Plating Code :  
A = Selective Gold flash over Nickel
- ④ Tail Type : V = Straight DIP Type  
H = Right Angle DIP Type
- ⑤ Insulator Color: 1 = Black ; 0 = White
- ⑥ Other Option : 000=Standard

CU04 Series Mini USB2.0 5 Circuits Receptacle SMT/DIP Connectors

- ⊙ High temperature plastic insulator
- ⊙ With fixed tabs and ground pegs
- ⊙ Grounding fingers provide locking feature and plug retention

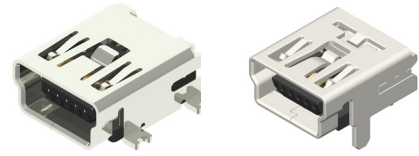

RoHS Compliant

P/N CU04S\*M15B0-0-NH

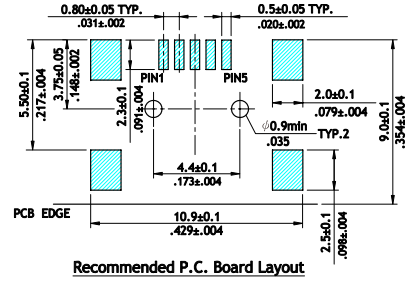
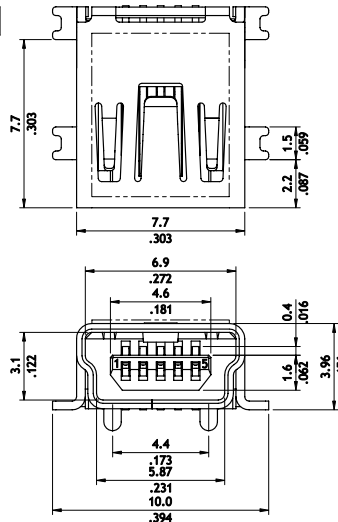

P/N CU04S\*H15BC-R0-NH

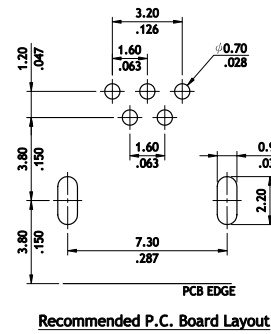
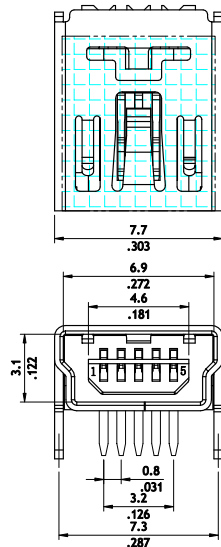

Ordering Code

① ② ③ ④ ⑤ ⑥ ⑦ ⑧ ⑨ ⑩  
**CU04 S A M 1 5 B 0 - R0 - NH**

- ① Series No.
- ② S = Receptacle
- ③ Plating Code :  
 A = Selective Gold flash over Nickel  
 C = Selective 30µ" Gold flash over Nickel
- ④ Tail Type: M = SMT Type  
 H = Right Angle DIP Type
- ⑤ Insulator Color: 1 = Black
- ⑥ No. of Circuits: 5 Pin
- ⑦ Type: B = B Type
- ⑧ Other Option: 0 = Standard ; C = Pin Length 2.1mm
- ⑨ Packing Options:  
 R0 = Tape & Reel (with Pick & Place Pad)  
 T0 = Tube
- ⑩ NH = For Lead Free soldering process and Halogen-Free

CU09 Series Micro USB2.0 Connectors

- ⊙ High temperature plastic for insulator
- ⊙ High durability and long cycle life



RoHS Compliant

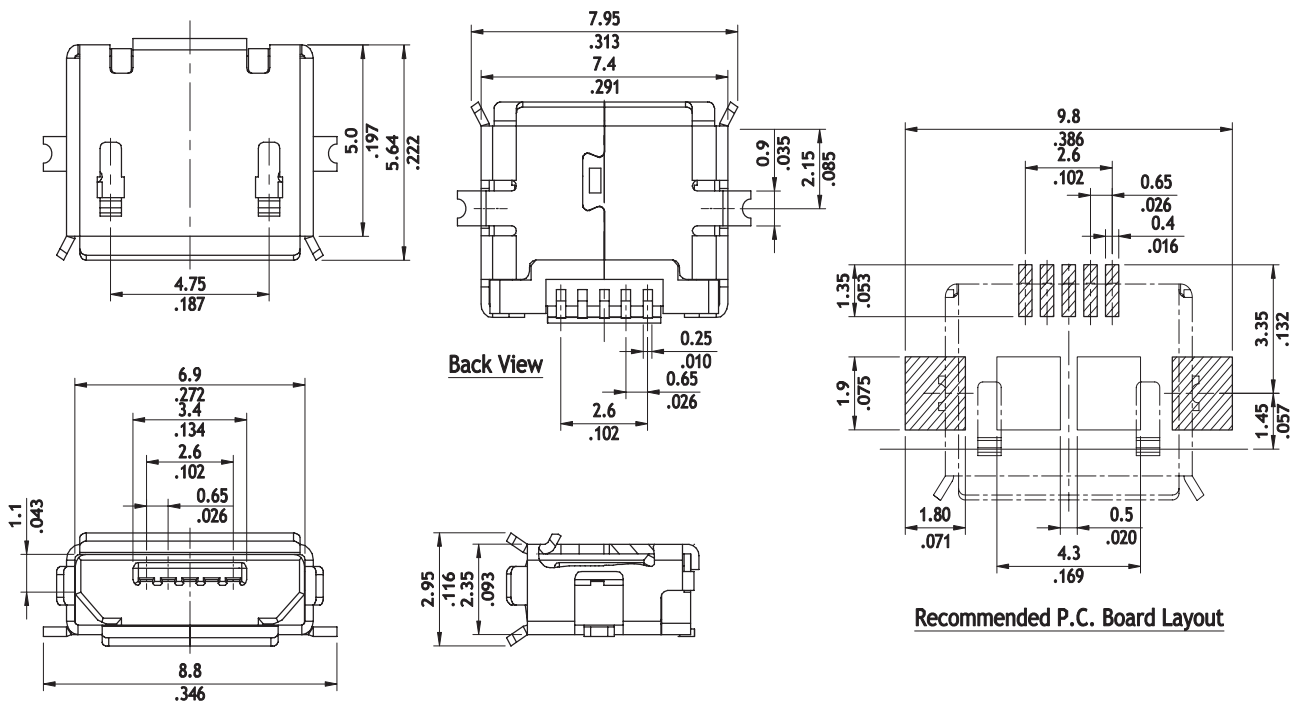

Ordering Code

①	②	③	④	⑤	⑥	⑦	⑧
CU09	S	2	M	1	5	C	0

- ① Series No.
- ② S = Socket
- ③ Plating Code :  
2 = Gold flash over Nickel
- ④ Tail Type: M = SMT Type
- ⑤ Insulator Color: 1 = Black
- ⑥ No. of Circuits: 5 Pin
- ⑦ Type: C = Micro USB 5 Pin Type-AB
- ⑧ Other Options: 0 = Standard



## CU05 Series IEEE 1394 Shielded I/O Receptacle Connectors

- ⊙ Available up-right angle version
- ⊙ With ground pegs
- ⊙ Provide the interface for speeds up to 400Mbps
- ⊙ Full metal shielding for ESD protection
- ⊙ High temperature plastic housing for SMT processing
- ⊙ Gold plated leaf contact withstand up to 1500 cycles
- ⊙ Polarized box shell design and lock grounding finger sense plug retention

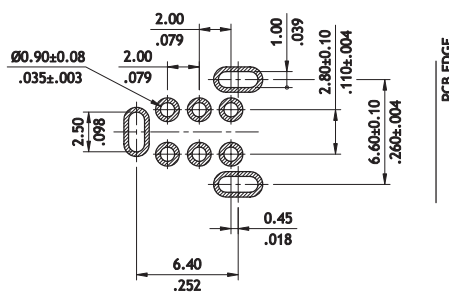
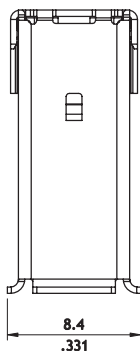
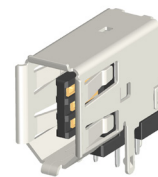

**Recommended P.C. Board Layout**  
(TOLERANCE: ±0.05)

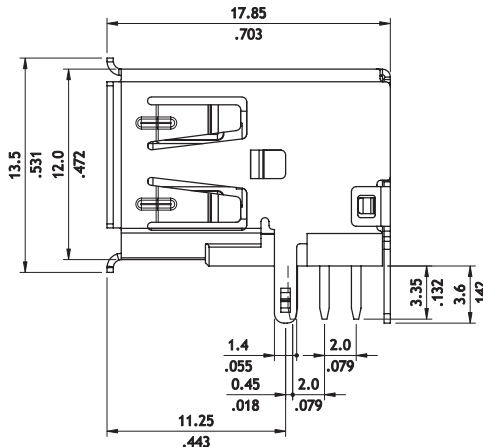
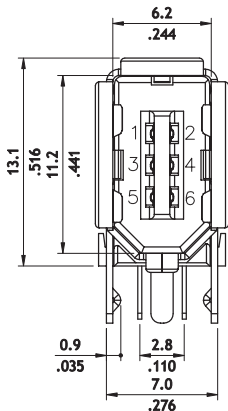

Ordering Code	①	②	③	④	⑤	⑥	⑦	⑧	⑨
	CU05	S	C	H	1	U	D0	R0	NH
① Series No.					⑤ Insulator Color: 1 = Black				
② S = Socket					⑥ Type: U = Upright Type				
③ Plating Code :					⑦ Options: D0 = Standard				
C = Selective 30μ" Gold flash over Nickel					⑧ Packing Option : R0 =Reel Packing				
*Optional plating available but MOQ requested					⑨ NH = For Lead Free wave flow soldering process and Halogen-Free				
④ Tail Type: H = Side Entry									

CU11 Series HDMI Receptacle Connectors

- ⊙ High temperature plastic insulator
- ⊙ With ground pegs

RoHS Compliant

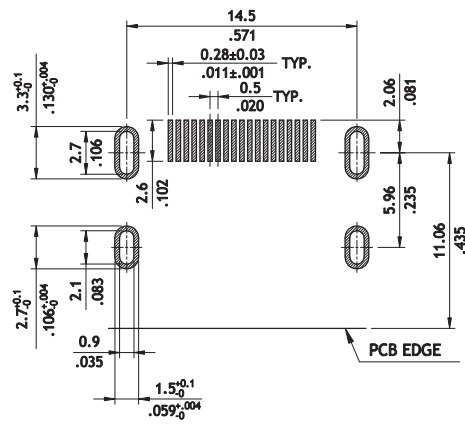
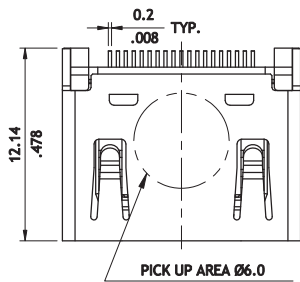

RECOMMENDED PCB LAYOUT  
TOLERANCE: ±0.05mm

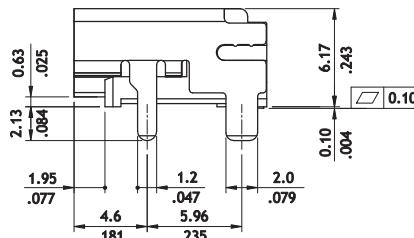
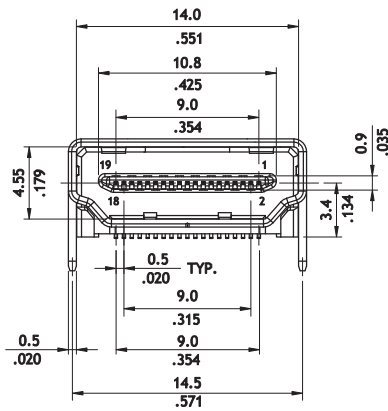

Ordering Code

① ② ③ ④ ⑤ ⑥ ⑦  
**CU11 S A M 1 0E0 - R 0**

- ① Series No.
- ② S = Socket
- ③ Plating Code :  
A = Selective Gold flash over Nickel
- ④ Tail Type: M = SMT Type
- ⑤ Insulator Color: 1 = Black
- ⑥ 0E0 = Standard
- ⑦ R0 = Tape & Reel

**USB 3.1 Type C Technical Specifications**

**NEW**

**Electrical Data-**

- Current rating: 3/5 Amps max
- Dielectric Withstanding: 100 VAC for one minute
- Contact Resistance:<40mΩ
- Insulation Resistance:>100MΩ
- Operating Temperature:-55°C to +85°C

MIDDLE MOUNT TYPE

Receptacle

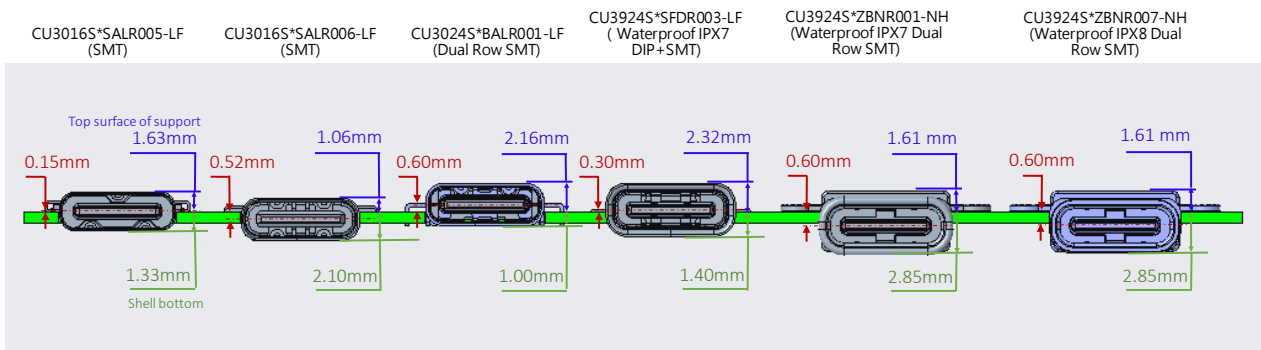

TOP MOUNT TYPE

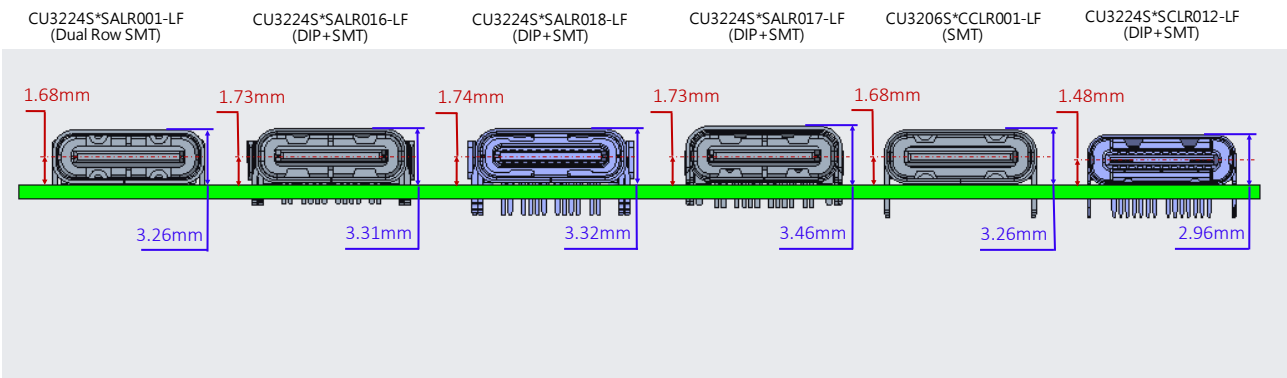

CU

I/O CONNECTORS



USB 3.1 Type C Technical Specifications

**NEW**

**Electrical Data-**

- Current rating: 5 Amps max
- Dielectric Withstanding: 100 VAC for one minute
- Contact Resistance: <40mΩ
- Insulation Resistance: >100MΩ
- Operating Temperature: -40°C to +80°C

TOP MOUNT TYPE+CLIP TYPE

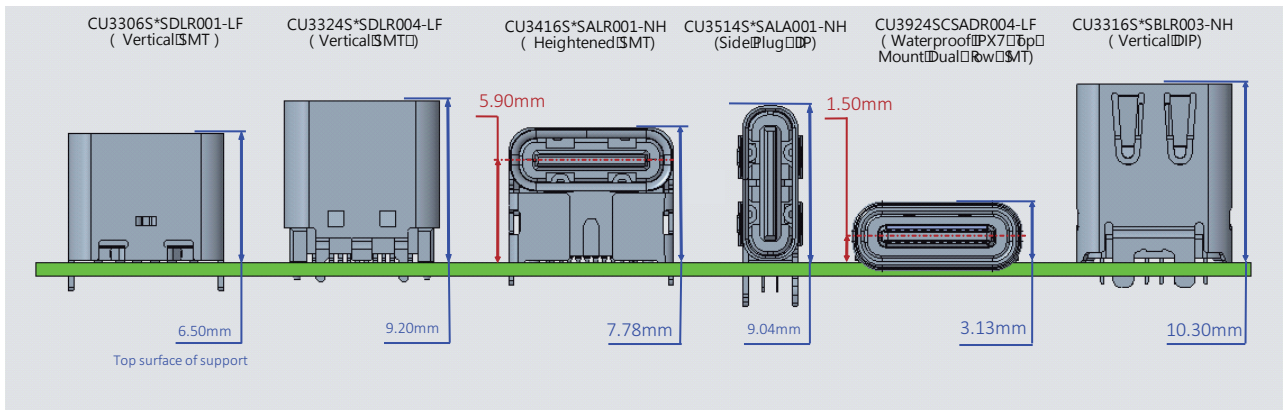
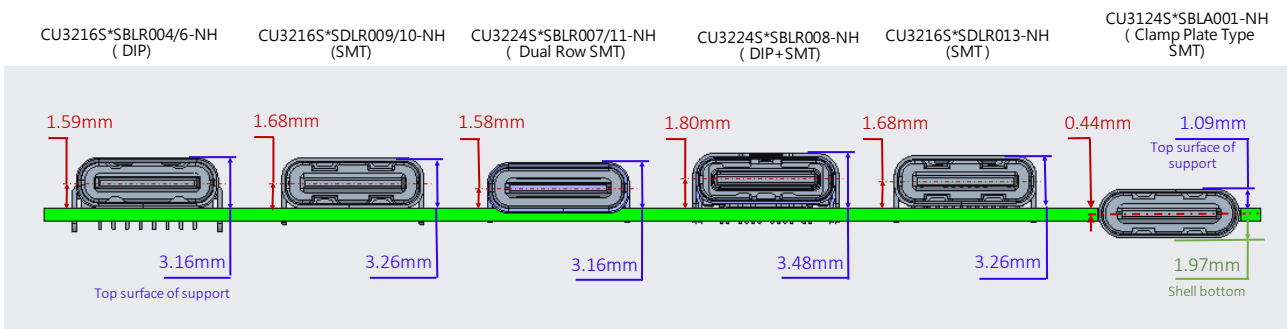

PLUG

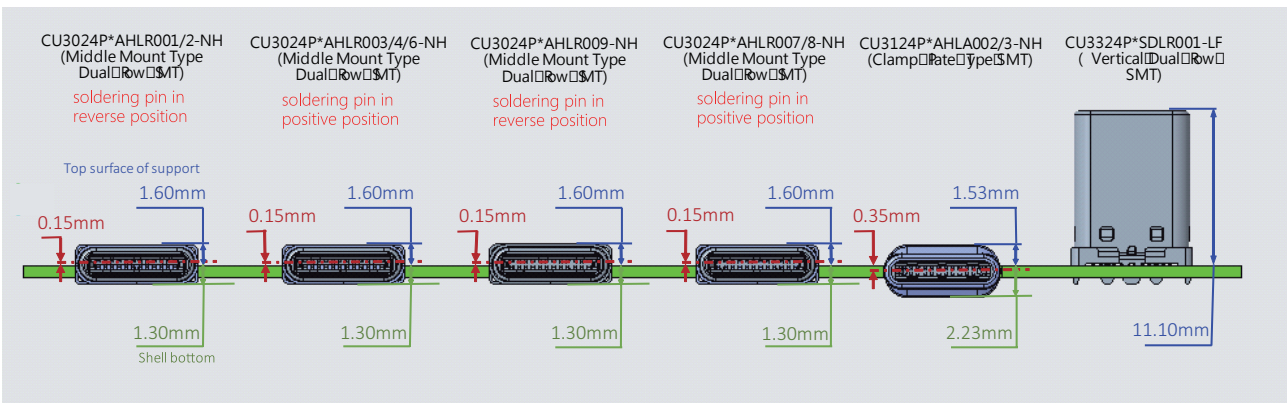

CU

I/O CONNECTORS

**CU30 Series USB 3.1 Type C Plug SMT Type Connectors (Reverse pin positon)**

- ⊙ Middle Mount Type
- ⊙ High temperature plastic insulator
- ⊙ Contact current rating:5Amperes max
- ⊙ Dielectric strength:100V AC.
- ⊙ Durability cycles:10000 cycles.
- ⊙ Compatible with wire and PCB side

**NEW**



RoHS Compliant

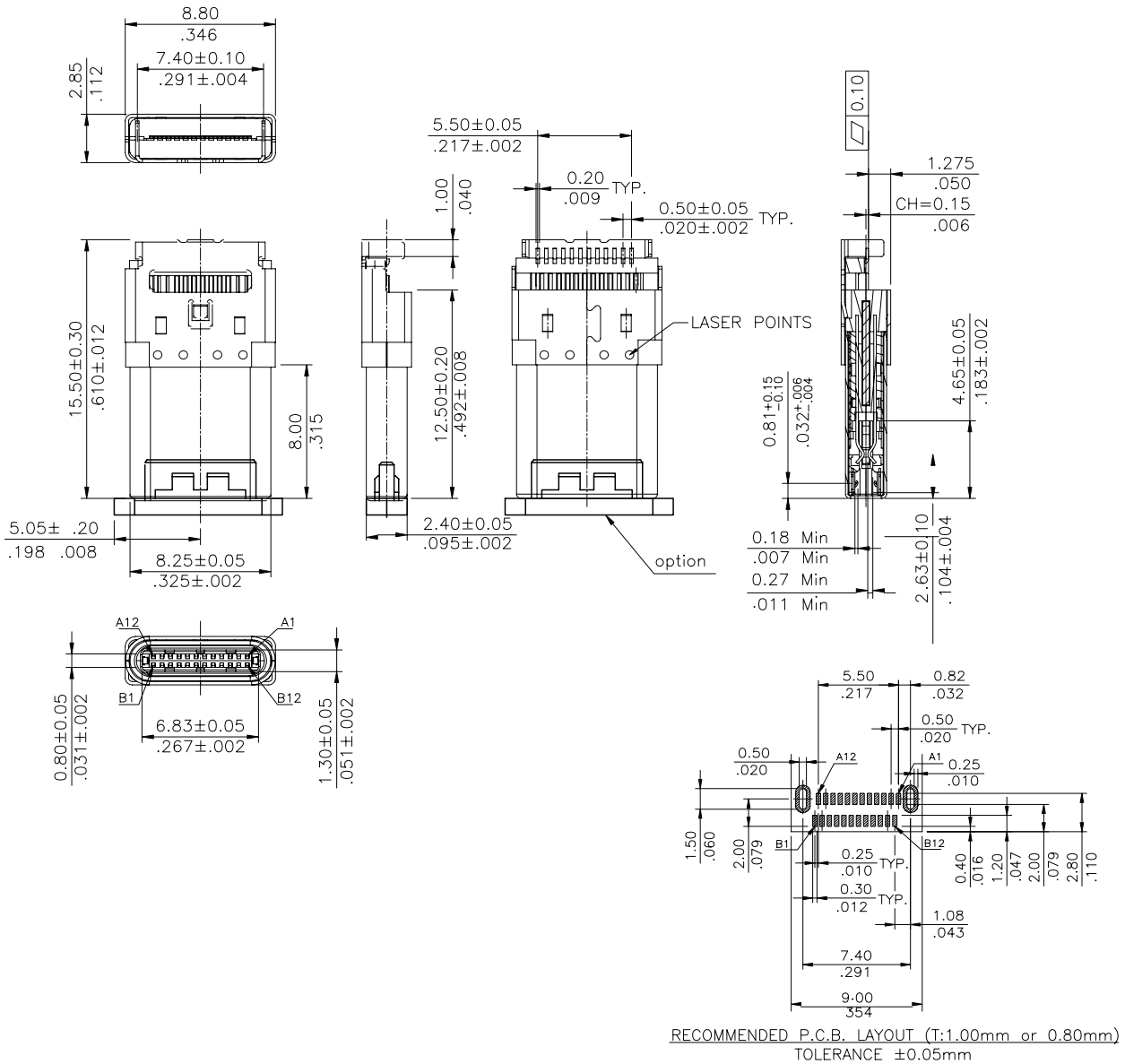

Ordering Code	①	②	③	④	⑤	⑥	⑦	⑧	⑨	⑩
	CU30	24	P	A	A	H	L	R	002	-NH

① Series No.  
 ② No. of Circuits  
 ③ P = Plug  
 ④ Plating Code :  
 A=Selective Gold Flash over Nickel  
 B=Selective 15µ" Gold flash over Nickel  
 C=Selective 30µ" Gold flash over Nickel  
 ⑤ Shell Material & Plating  
 A= Stainless Steel Nickel Plating  
 ⑥ Contact Material : H = Copper Alloy  
 ⑦ Insulator Material & Color option  
 L= LCP , Black  
 ⑧ Packing : R =Tape & Reel  
 ⑨ 001=Without Cover  
 002=With Cover  
 ⑩ NH = For Lead Free soldering process a and Halogen-Free

CU  
I/O CONNECTORS

CU30 Series USB 3.1 Type C Plug SMT Type Connectors (Parallel pin position)

- ⊙ Middle Mount Type
- ⊙ High temperature plastic insulator
- ⊙ Contact current rating:3Amperes max
- ⊙ Dielectric strength:100V AC.
- ⊙ Durability cycles:10000 cycles.
- ⊙ Compatible with wire and PCB side

**NEW**



RoHS Compliant

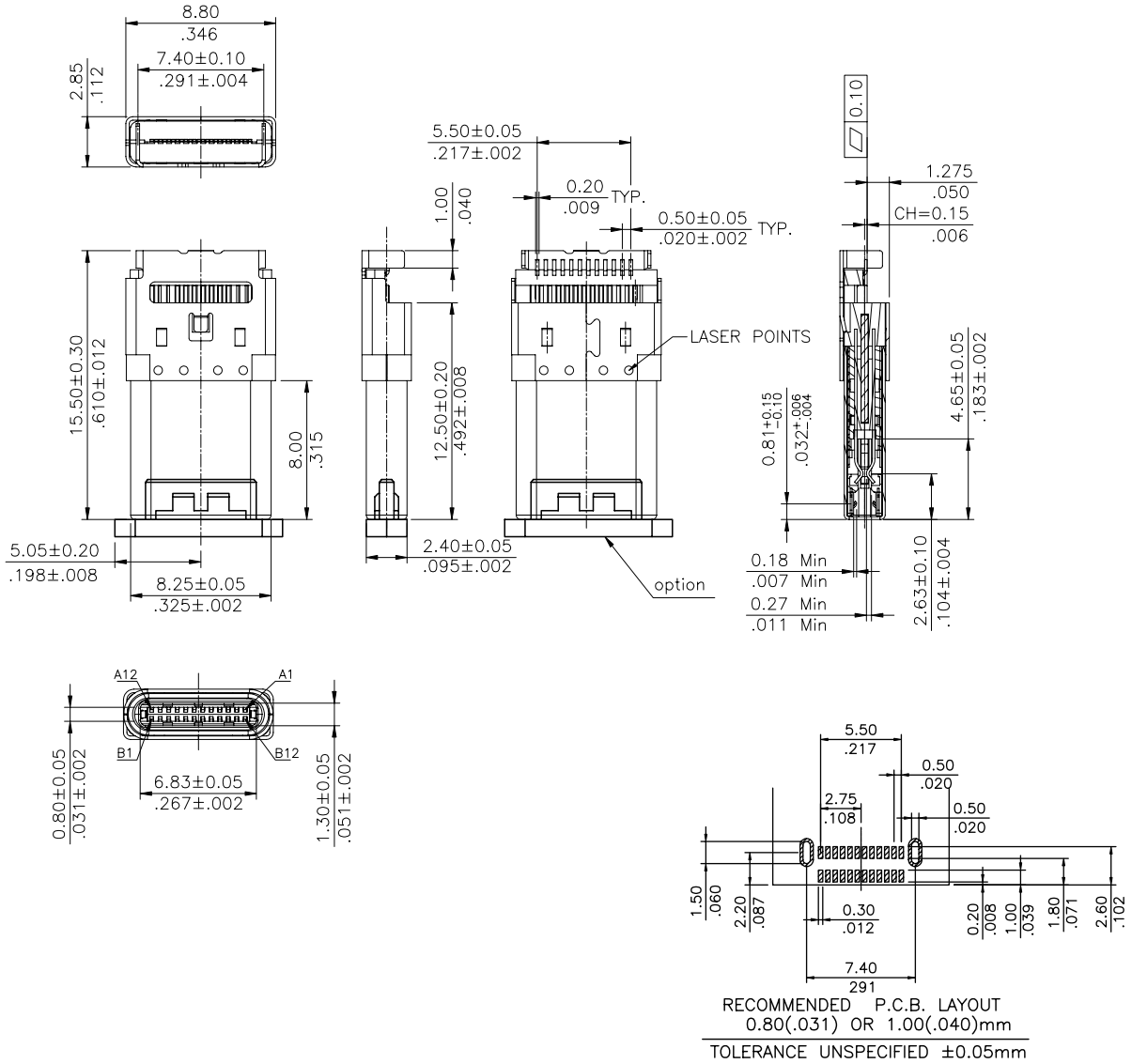

Ordering Code

① ② ③ ④ ⑤ ⑥ ⑦ ⑧ ⑨ ⑩  
**CU30 24 P A A H L R 003 - NH**

- ① Series No.
- ② No. of Circuits
- ③ P = Plug
- ④ Plating Code  
A=Selective Gold Flash over Nickel  
B=Selective 15µ" Gold flash over Nickel  
C=Selective 30µ" Gold flash over Nickel
- ⑤ Shell Material & Plating  
A= Stainless Steel Nickel Plating
- ⑥ Contact Material : H = Copper Alloy
- ⑦ Insulator Material & Color option  
L= LCP , Black
- ⑧ Packing R =Tape & Reel
- ⑨ 003=Without Cover  
004=With Cover  
006=With cover attach Back shell
- ⑩ NH = For Lead Free soldering process and Halogen-Free  
\*Special options consult manufacturer



**CU30 Series USB 3.1 Type C Plug SMT Type Connectors**

- ⊙ Middle Mount Type
- ⊙ High temperature plastic insulator
- ⊙ Contact current rating :3 Amperes max
- ⊙ Dielectric strength:100V AC.
- ⊙ Durability cycles:10000 cycles.
- ⊙ Compatible with wire and PCB side



RoHS Compliant

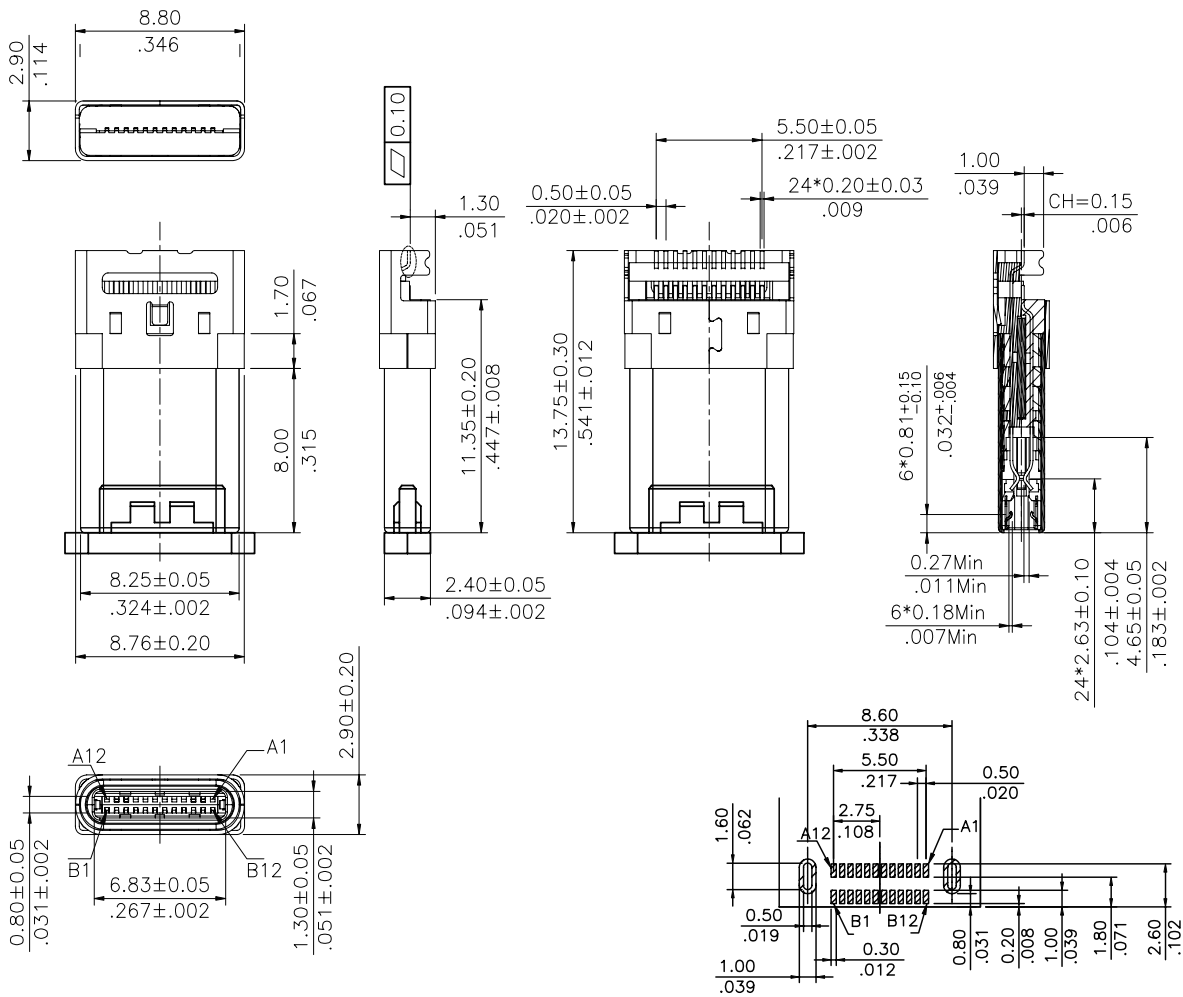

RECOMMENDED P.C.B. LAYOUT  
0.80(.031) OR 1.00(.040)mm  
TOLERANCE UNSPECIFIED ±0.05mm

Ordering Code	①	②	③	④	⑤	⑥	⑦	⑧	⑨	⑩
	CU30	24	P	A	A	H	L	R	007	- NH

① Series No.  
 ② No. of Circuits  
 ③ P = Plug  
 ④ Plating Code :  
 A=Selective Gold Flash over Nickel  
 B=Selective 15µ" Gold flash over Nickel  
 C=Selective 30µ" Gold flash over Nickel  
 ⑤ Shell Material & Plating  
 A= Stainless Steel Nickel Plating  
 ⑥ Contact Material : H = Copper Alloy  
 ⑦ Insulator Material &Color option  
 L= LCP , Black  
 ⑧ Packing : R =Tape & Reel  
 ⑨ 007=With Cover  
 008=Without cover  
 ⑩ NH = For Lead Free soldering process and Halogen-Free

CU30 Series USB 3.1 Type C Plug SMT Type Connectors

- ⊙ Middle Mount Type
- ⊙ High temperature plastic insulator
- ⊙ Contact current rating:3 Amperes max
- ⊙ Dielectric strength:100V AC.
- ⊙ Durability cycles:10000 cycles.
- ⊙ Compatible with wire and PCB side

**NEW**



RoHS Compliant

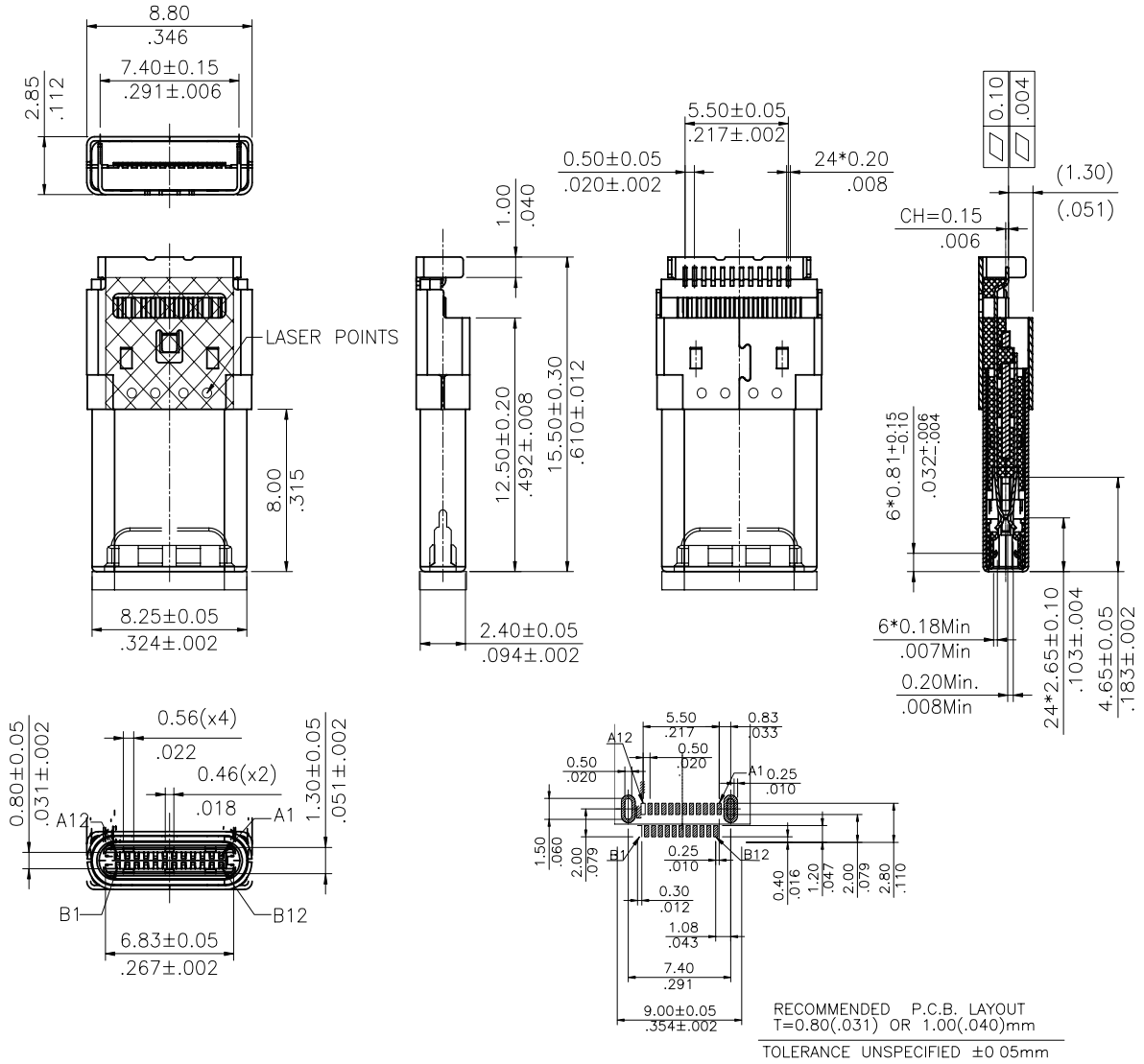

Ordering Code

①	②	③	④	⑤	⑥	⑦	⑧	⑨	⑩
CU30	24	P	A	A	H	L	R	009	NH

- ① Series No.
- ② No. of Circuits
- ③ P = Plug
- ④ Plating Code :  
A=Selective Gold Flash over Nickel  
B=Selective 15µ" Gold flash over Nickel  
C=Selective 30µ" Gold flash over Nickel
- ⑤ Shell Material & Plating  
A= Stainless Steel Nickel Plating
- ⑥ Contact Material : H = Copper Alloy
- ⑦ Insulator Material &Color option  
L= LCP , Black
- ⑧ Packing : R =Tape & Reel
- ⑨ Other Oprion : 009
- ⑩ NH = For Lead Free soldering process and Halogen-Free

CU

I/O CONNECTORS

**CU30 Series USB 3.1 Type C Receptacle SMT Type Connectors**

- ⊙ Middle Mount Type
- ⊙ High temperature plastic insulator
- ⊙ Contact current rating : 5 Amperes max
- ⊙ Dielectric strength:100V AC.
- ⊙ Durability cycles:10000 cycles.

**NEW**

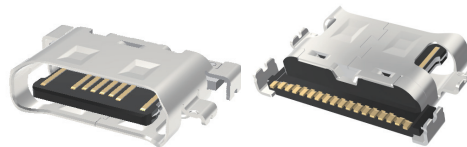

RoHS Compliant

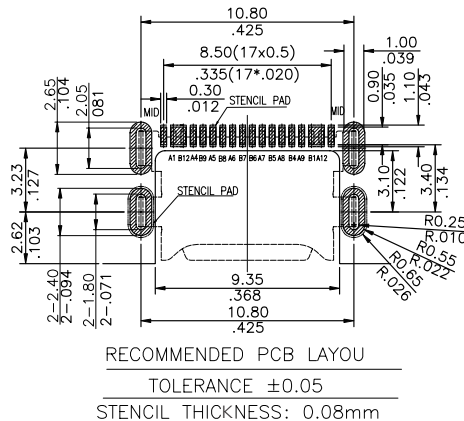
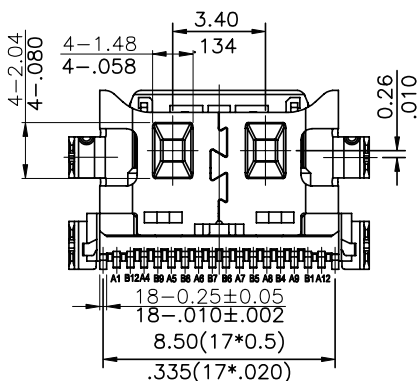
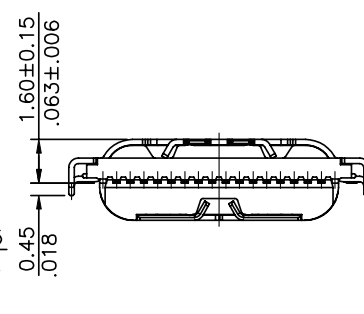
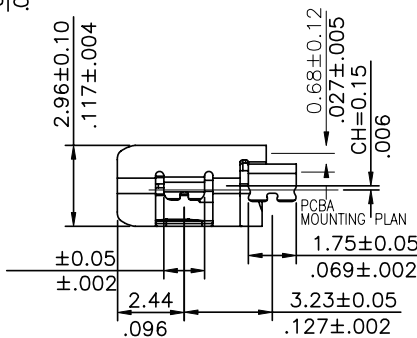
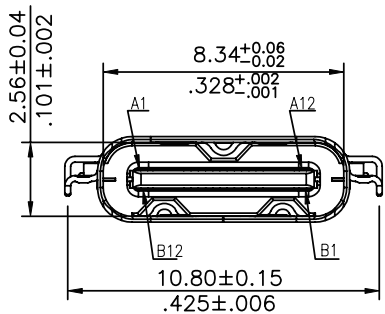
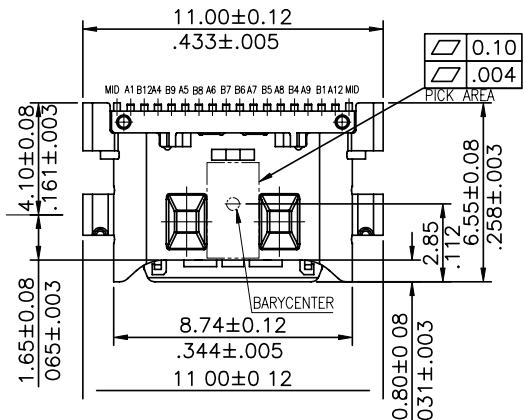

**Ordering Code**

①	②	③	④	⑤	⑥	⑦	⑧	⑨	⑩
CU30	16	S	2	S	A	L	R	005	- LF

- ① Series No.
- ② No. of Circuits
- ③ S = Socket
- ④ Plating Code :  
2 = Gold Flash over Nickel
- ⑤ Shell Material & Plating  
S= Stainless Steel
- ⑥ Contact Material : A = Copper Alloy
- ⑦ Insulator Material & Color option  
L= LCP , Black
- ⑧ Packing : R = Tape & Reel
- ⑨ Other Option : 005
- ⑩ LF = For Lead Free Soldering process

CU

I/O CONNECTORS



CU30 Series USB 3.1 Type C Receptacle SMT Type Connectors

- ⊙ Middle Mount Type
- ⊙ High temperature plastic insulator
- ⊙ Contact current rating : 5 Amperes max
- ⊙ Dielectric strength:100V AC.
- ⊙ Durability cycles:10000 cycles.

**NEW**

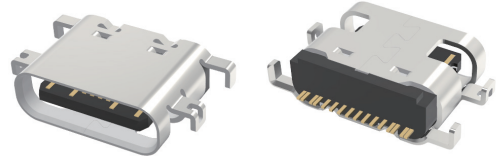

RoHS Compliant

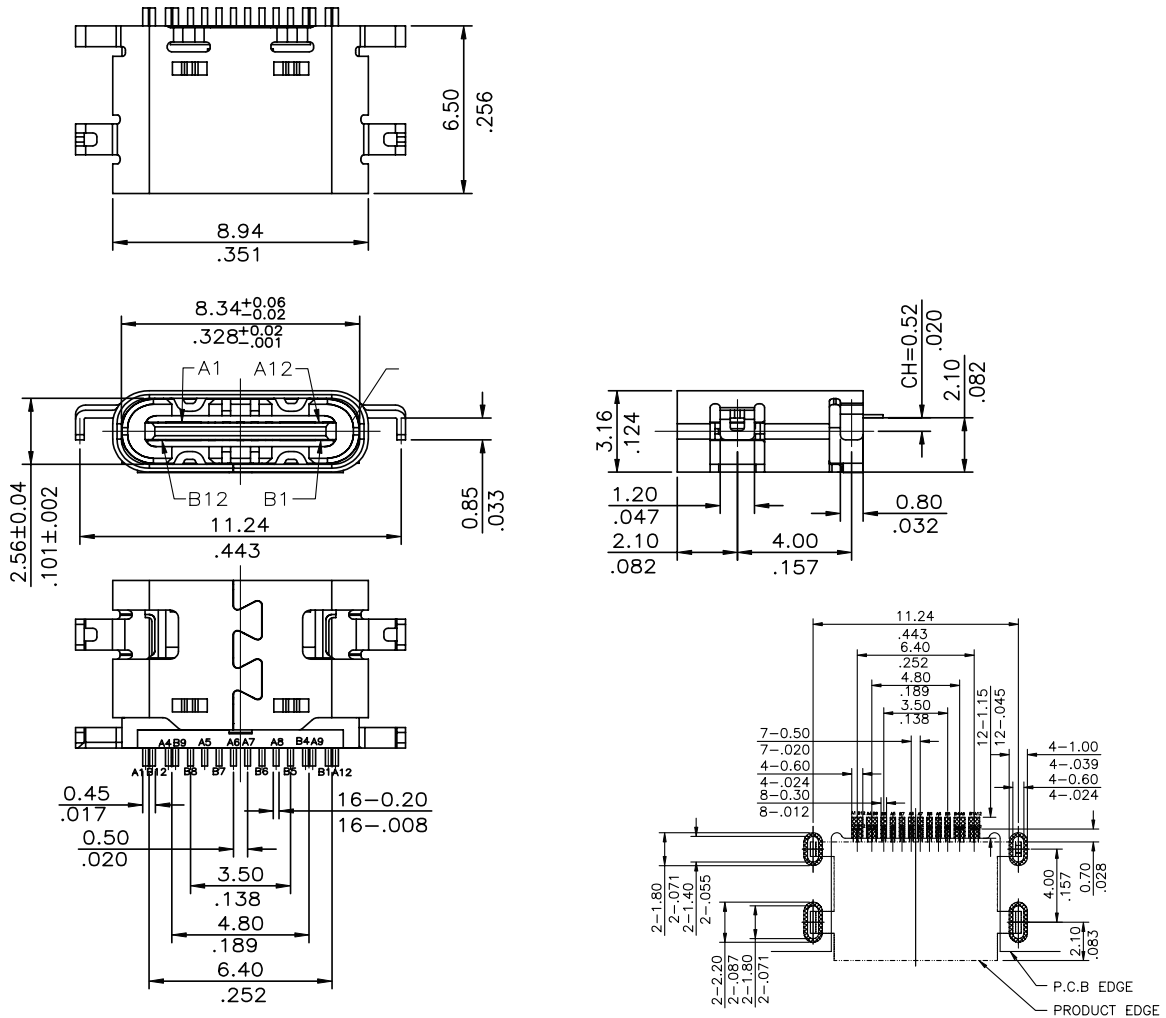

RECOMMENDED P.C.B. LAYOUT (T:0.80mm)  
TOLERANCE UNSPECIFIED ±0.05mm

Ordering Code

① ② ③ ④ ⑤ ⑥ ⑦ ⑧ ⑨ ⑩  
**CU30 16 S A S A L R 006 - LF**

- ① Series No.
- ② No. of Circuits
- ③ S = Socket
- ④ Plating Code :  
 A=Selective Gold Flash over Nickel  
 B=Selective 15µ" Gold flash over Nickel  
 C=Selective 30µ" Gold flash over Nickel  
 2=Gold Flash over Nickel
- ⑤ Shell Material & Plating  
 S= Stainless Steel
- ⑥ Contact Material : A = Copper Alloy
- ⑦ Insulator Material &Color option  
 L= LCP , Black
- ⑧ Packing : R = Tape & Reel
- ⑨ Other Option : 006
- ⑩ LF = For Lead Free Soldering process

CU

I/O CONNECTORS

**CU30 Series USB 3.1 Type C Receptacle SMT Type Connectors**

- ⊙ Middle Mount Type
- ⊙ High temperature plastic insulator
- ⊙ Contact current rating : 3 Amperes max
- ⊙ Dielectric strength:100V AC.
- ⊙ Durability cycles:10000 cycles.

**NEW**

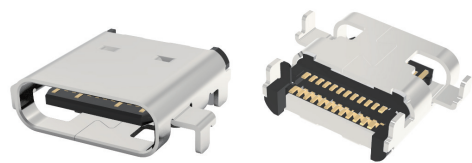

RoHS Compliant

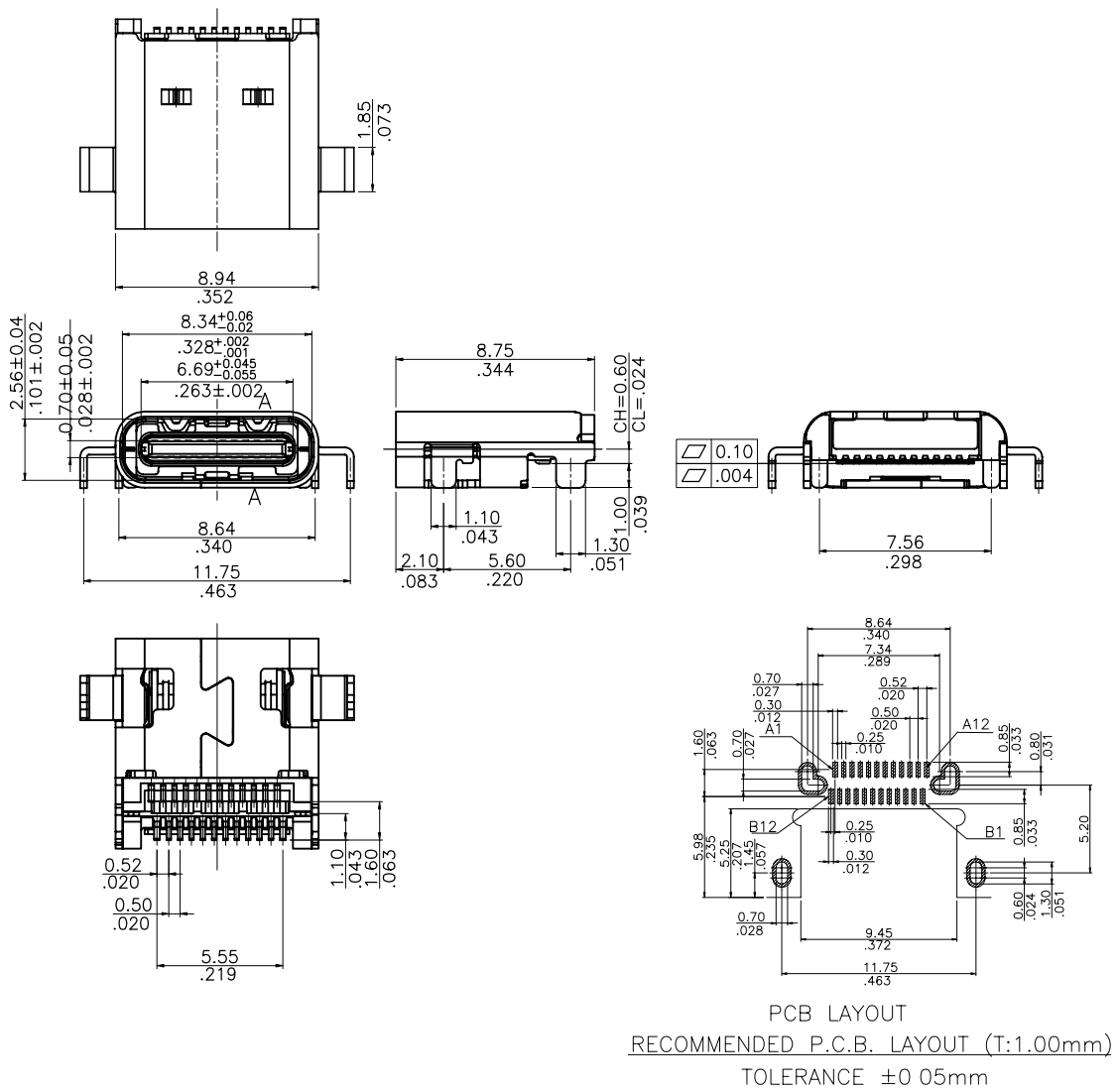

Ordering Code	①	②	③	④	⑤	⑥	⑦	⑧	⑨	⑩
	CU30	24	S	A	B	A	L	R	001	LF
① Series No.										
② No. of Circuits										
③ S = Socket										
④ Plating Code :										
A=Selective Gold Flash over Nickel										
B=Selective 15μ" Gold flash over Nickel										
C=Selective 30μ" Gold flash over Nickel										
⑤ Shell Material & Plating										
B= Stainless Steel										
⑥ Contact Material : A = Copper Alloy										
⑦ Insulator Material &Color option										
L= LCP , Black										
⑧ Packing : R = Tape & Reel										
⑨ Other Oprion : 001										
⑩ LF = For Lead Free Soldering process										

CU  
I/O CONNECTORS

CU31 Series USB 3.1 Type C Plug Clamp Type Connectors

- ⊙ Clamp Plate Type
- ⊙ High temperature plastic insulator
- ⊙ Contact current rating : 5 Amperes max
- ⊙ Dielectric strength:100V AC.
- ⊙ Durability cycles:10000 cycles.

**NEW**



RoHS Compliant

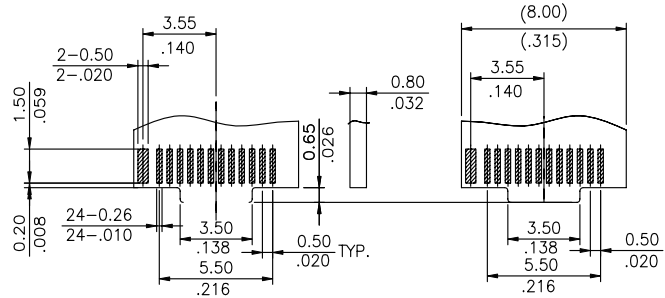
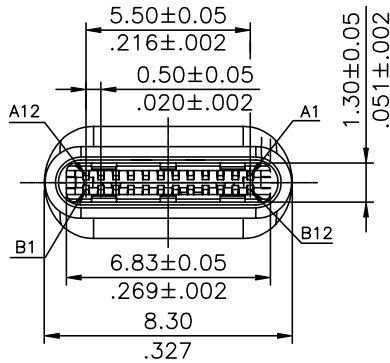
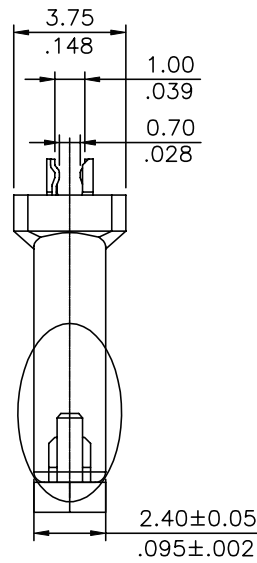
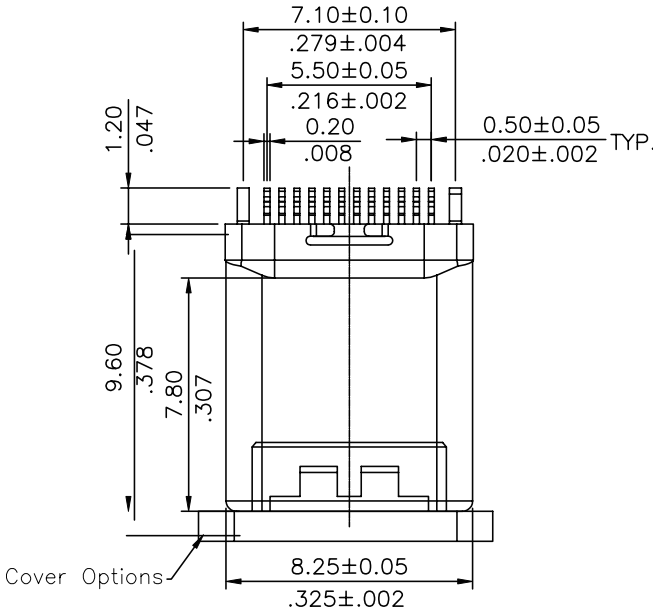

RECOMMENDED P.C.B. LAYOUT  
TOLERANCE UNSPECIFIED ±0.05mm

Ordering Code

① ② ③ ④ ⑤ ⑥ ⑦ ⑧ ⑨ ⑩  
CU31 24 P A A H L A 003 - NH

- ① Series No.
- ② No. of Circuits
- ③ P = Plug
- ④ Plating Code :  
A=Selective Gold Flash over Nickel  
B=Selective 15µ" Gold flash over Nickel  
C=Selective 30µ" Gold flash over Nickel
- ⑤ Shell Material & Plating  
A= Stainless Steel Nickel Plating
- ⑥ Contact Material : H = Copper Alloy
- ⑦ Insulator Material &Color option  
L= LCP , Black
- ⑧ Packing : A = Tray
- ⑨ 002=Without Cover  
003=With Cover
- ⑩ NH = For Lead Free soldering process and Halogen-Free  
\*Special options consult manufacturer



**CU31 Series USB Type C Female Clamp Type Connectors**

- ⊙ Clamp Plate Type
- ⊙ High temperature plastic insulator
- ⊙ Contact current rating : 5 Amperes max
- ⊙ Dielectric strength:100V AC.
- ⊙ Durability cycles:10000 cycles.

**NEW**



RoHS Compliant

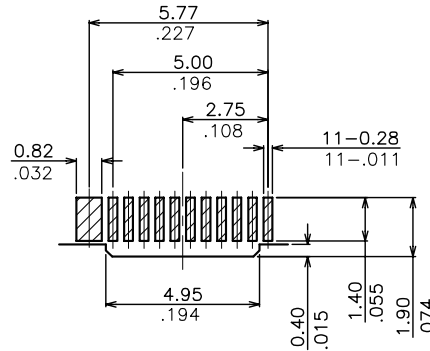
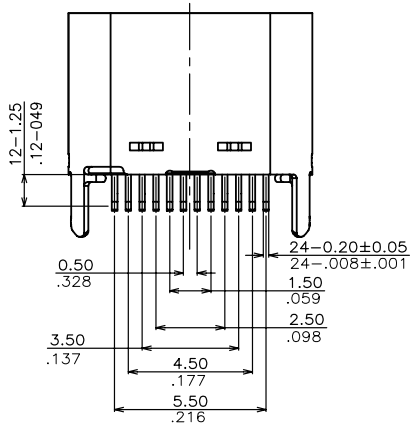
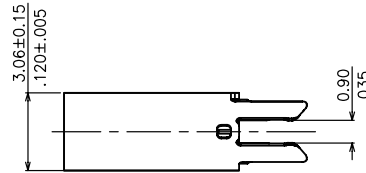
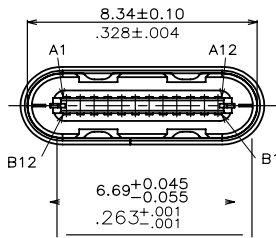
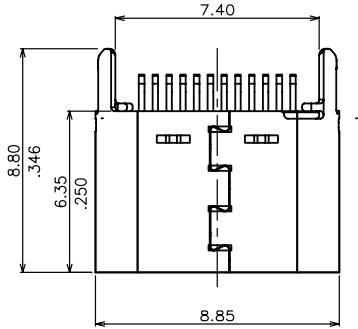

RECOMMENDED P.C.B. LAYOUT  
TOLERANCE UNSPECIFIED ±0.05mm

**Ordering Code**

① ② ③ ④ ⑤ ⑥ ⑦ ⑧ ⑨ ⑩  
**CU31 24 S A S B L A 001-NH**

- ① Series No.
- ② No. of Circuits
- ③ S = Socket
- ④ Plating Code :  
 A=Selective Gold Flash over Nickel  
 B=Selective 15µ" Gold flash over Nickel  
 C=Selective 30µ" Gold flash over Nickel
- ⑤ Shell Material & Plating  
 S= Stainless Steel
- ⑥ Contact Material : B= Copper Alloy
- ⑦ Insulator Material & Color Option  
 L=LCP Black
- ⑧ Packing : A =Tray
- ⑨ Other Option : 001
- ⑩ NH = For Lead Free soldering process and Halogen-Free







CU32 Series USB Type C Female SMT Type Connectors

- ⊙ Top Mount Type + SMT Type
- ⊙ High temperature plastic insulator
- ⊙ Contact current rating : 5 Amperes max
- ⊙ Dielectric strength:100V AC.
- ⊙ Durability cycles:10000 cycles

**NEW**



RoHS Compliant

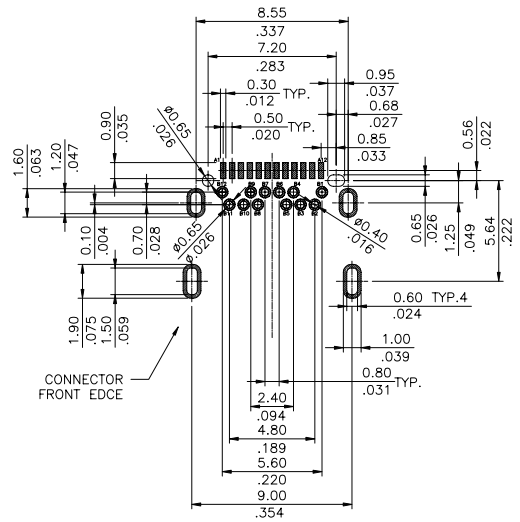
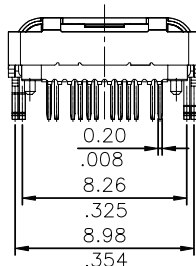
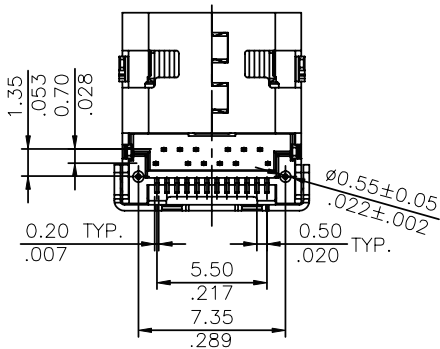
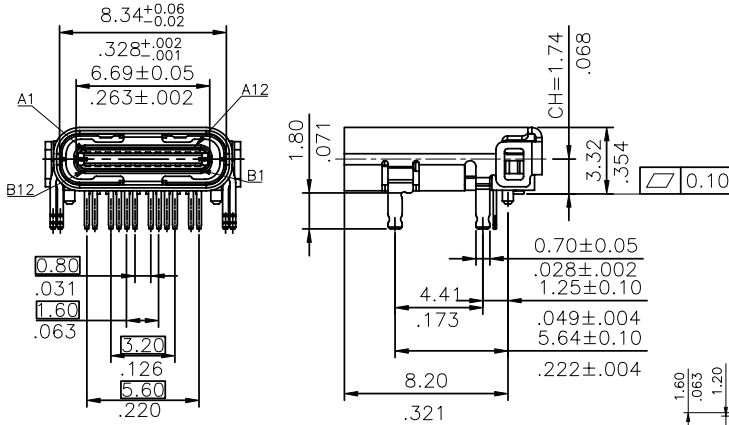
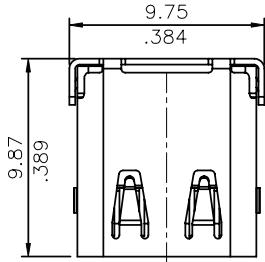

RECOMMENDED P.C.B. LAYOUT (T:1.60mm)  
TOLERANCE ±0.05mm

Ordering Code

①	②	③	④	⑤	⑥	⑦	⑧	⑨	⑩
CU32	24	S	A	S	A	L	R	018	LF

- ① Series No.
- ② No. of Circuits : 24
- ③ S = Socket
- ④ Plating Code :  
A=Selective Gold Flash over Nickel
- ⑤ Shell Material & Plating: S= Stainless Steel
- ⑥ Contact Material : A=Copper Alloy
- ⑦ Insulator Color & Color Option: L = LCP , Black
- ⑧ Packing : R=Tape & Reel
- ⑨ Other Option : 018
- ⑩ LF = For Lead Free Soldering process

**CU32 Series USB Type C Female SMT Type Connectors**

- ⊙ Top Mount Type + SMT Type
- ⊙ High temperature plastic insulator
- ⊙ Contact current rating : 5 Amperes max
- ⊙ Dielectric strength:100V AC.
- ⊙ Durability cycles:10000 cycles

**NEW**

RoHS Compliant

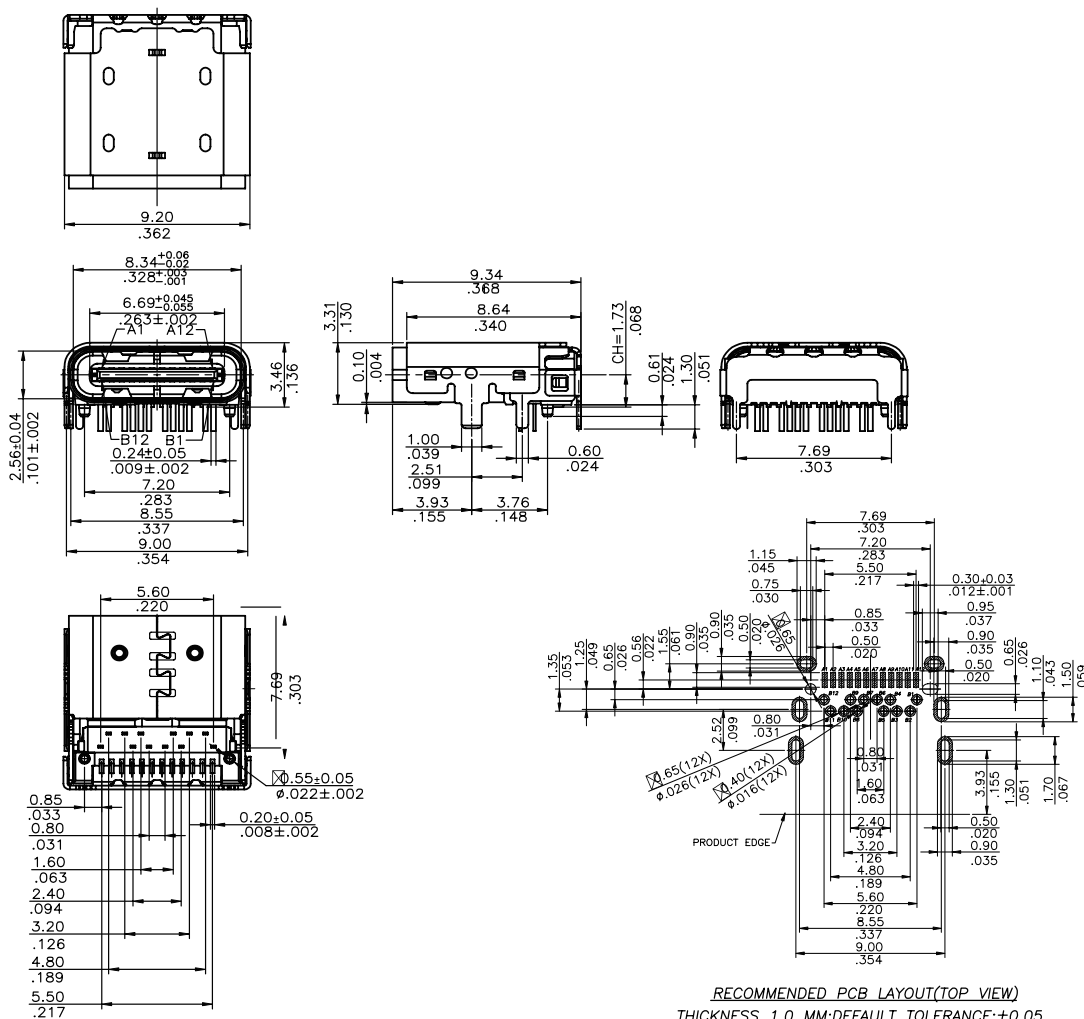

<b>Ordering Code</b>	①	②	③	④	⑤	⑥	⑦	⑧	⑨	⑩
	CU32	24	S	2	S	A	L	R	017	-LF

① Series No.  
 ② No. of Circuits  
 ③ S = Socket  
 ④ Plating Code :  
 2=Selective Gold Flash over Nickel  
 ⑤ Shell Material & Plating:  
 S= Stainless Steel  
 ⑥ Contact Material : A=Copper Alloy  
 ⑦ Insulator Color & Color Option: L= LCP , Black  
 ⑧ Packing : R=Tape & Reel  
 ⑨ Other Option : 017  
 ⑩ LF = For Lead Free Soldering process

CU I/O CONNECTORS

**CU32 Series USB2.0 Type C Female SMT Type Connectors**

- ⊙ Top Mount SMT +SMT Type
- ⊙ High temperature plastic insulator
- ⊙ Contact current rating : 5 Amperes max
- ⊙ Dielectric strength:100V AC.
- ⊙ Durability cycles:10000 cycles

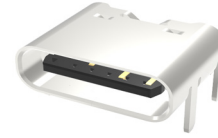

RoHS Compliant

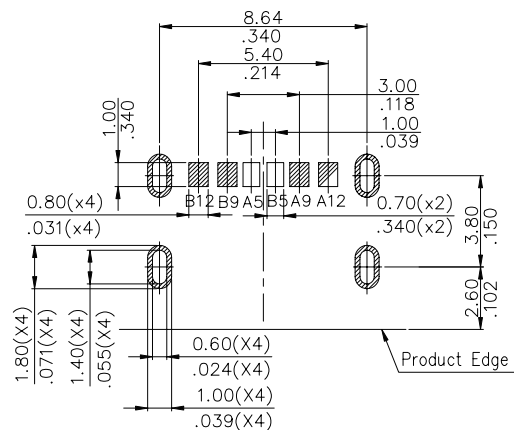
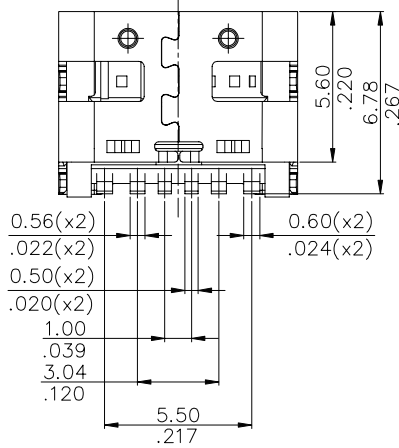
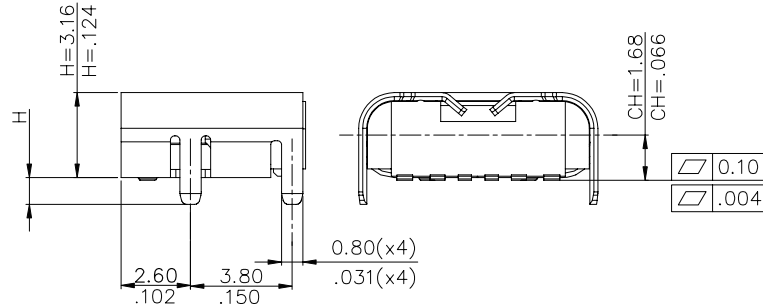
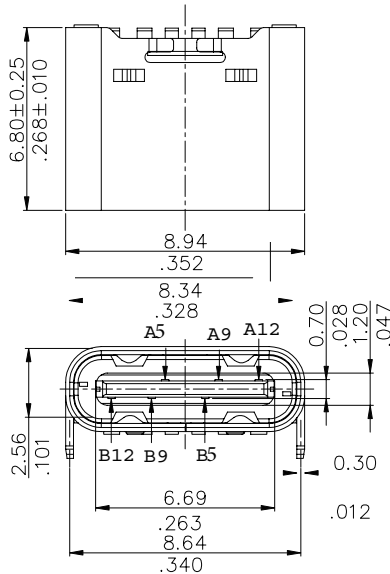

RECOMMENDED P.C.B. LAYOUT  
TOLERANCE UNSPECIFIED ±0.05mm

**Ordering Code**

① ② ③ ④ ⑤ ⑥ ⑦ ⑧ ⑨ ⑩  
**CU32 06 S A C C L R 001 - LF**

- ① Series No.
- ② No. of Circuits
- ③ S = Socket
- ④ Plating Code :  
 A=Selective Gold Flash over Nickel  
 B=Selective 15µ" Gold flash over Nickel  
 C=Selective 30µ" Gold flash over Nickel
- ⑤ Shell Material & Plating  
 C = Stainless Steel
- ⑥ Contact Material: C=Copper Alloy
- ⑦ Insulator Material & Color Option  
 L=LCP Black
- ⑧ Packing : R= Tape & Reel
- ⑨ 001=H:1.0mm , 002=H:2.0mm
- ⑩ LF = For Lead Free Soldering process



**CU32 Series USB2.0 Type C Female SMT Type Connectors**

- ⊙ Top Mount Type + SMT Type
- ⊙ High temperature plastic insulator
- ⊙ Contact current rating : 5 Amperes max
- ⊙ Dielectric strength:100V AC.
- ⊙ Durability cycles:10000 cycles

**NEW**

RoHS Compliant

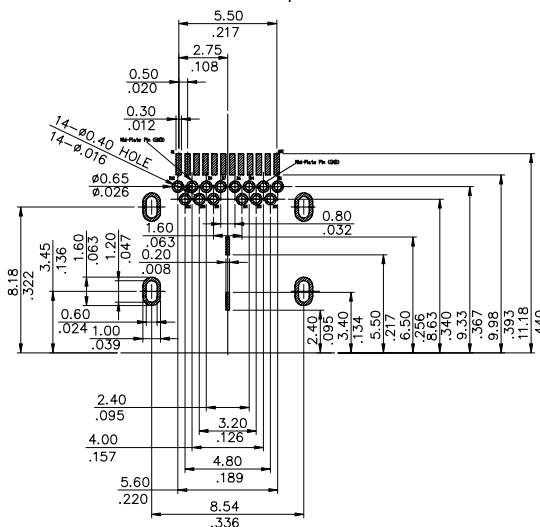
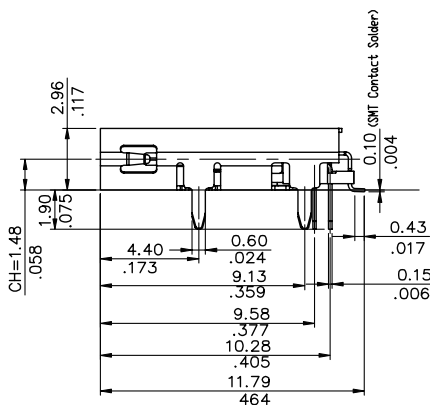
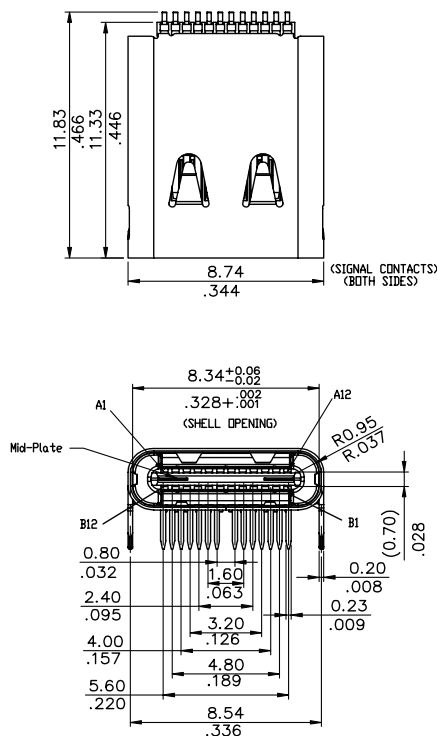
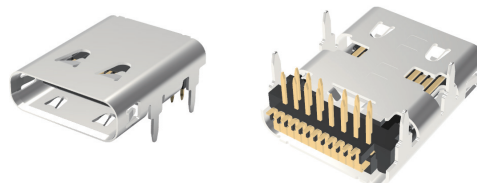

RECOMMENDED PCB LAYOUT (COMPONENT SIDE)  
 PCB THICKNESS: 1.0 For 1.5 Solder tail  
 1.6 for 1.9 solder tail  
 DEFAULT TOLERANCE: ±0.05

Ordering Code	①	②	③	④	⑤	⑥	⑦	⑧	⑨	⑩
	CU32	24	S	A	S	C	L	R	012	LF
① Series No.										
② No. of Circuits										
③ S = Socket										
④ Plating Code : A=Selective Gold Flash over Nickel										
⑤ Shell Material & Plating S = Stainless Steel										
⑥ Contact Material : C= Copper Alloy										
⑦ Insulator Material & Color Option L=LCP Black										
⑧ Packing : R =Tape & Reel										
⑨ Other Option : 012										
⑩ LF = For Lead Free Soldering process										

CU  
I/O CONNECTORS

CU32 Series USB2.0 Type C Female SMT Type Connectors

- ⊙ Top Mount SMT Type
- ⊙ High temperature plastic insulator
- ⊙ Contact current rating : 5 Amperes max
- ⊙ Dielectric strength:100V AC.
- ⊙ Durability cycles:10000 cycles

**NEW**

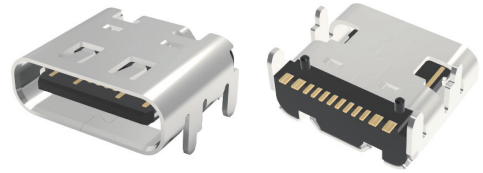

RoHS Compliant 

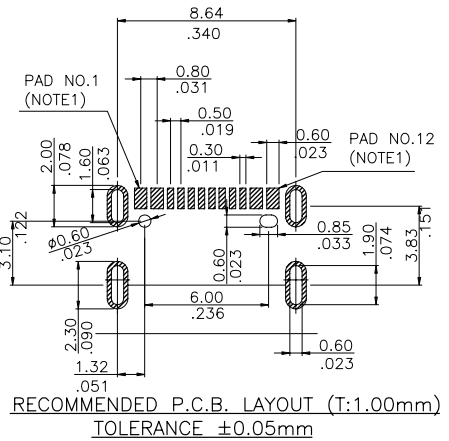
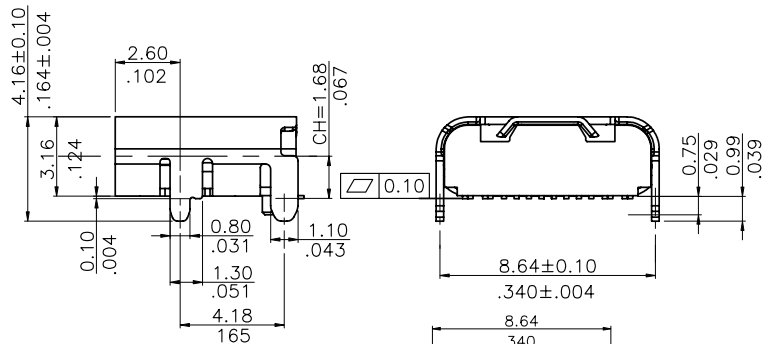
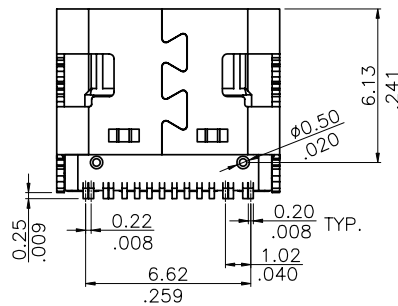
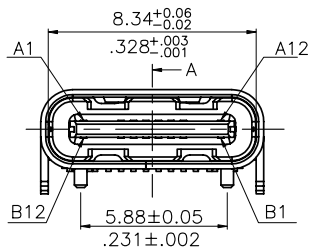
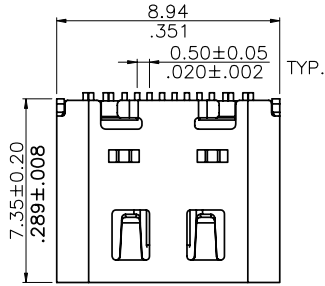

Ordering Code

① ② ③ ④ ⑤ ⑥ ⑦ ⑧ ⑨ ⑩  
**CU32 16 S 2 S D L R 013 - NH**

- ① Series No.
- ② No. of Circuits
- ③ S = Socket
- ④ Plating Code :  
A=Selective Gold Flash over Nickel  
2=Gold Flash over Nickel
- ⑤ Shell Material & Plating  
S = Stainless steel
- ⑥ Contact Material: D=Copper Alloy
- ⑦ Insulator Material & Color Option  
L=LCP Black
- ⑧ Packing : R= Tape & Reel
- ⑨ Other Option : 013
- ⑩ NH = For Lead Free soldering process and Halogen-Free

**CU32 Series USB2.0 Type C Female SMT Type Connectors**

- ⊙ Top Mount DIP Type
- ⊙ High temperature plastic insulator
- ⊙ Contact current rating : 5 Amperes max
- ⊙ Dielectric strength:100V AC.
- ⊙ Durability cycles:10000 cycles

**NEW**

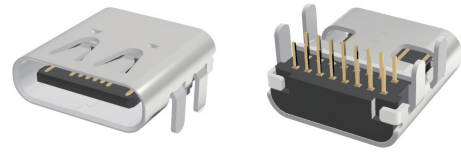

RoHS Compliant

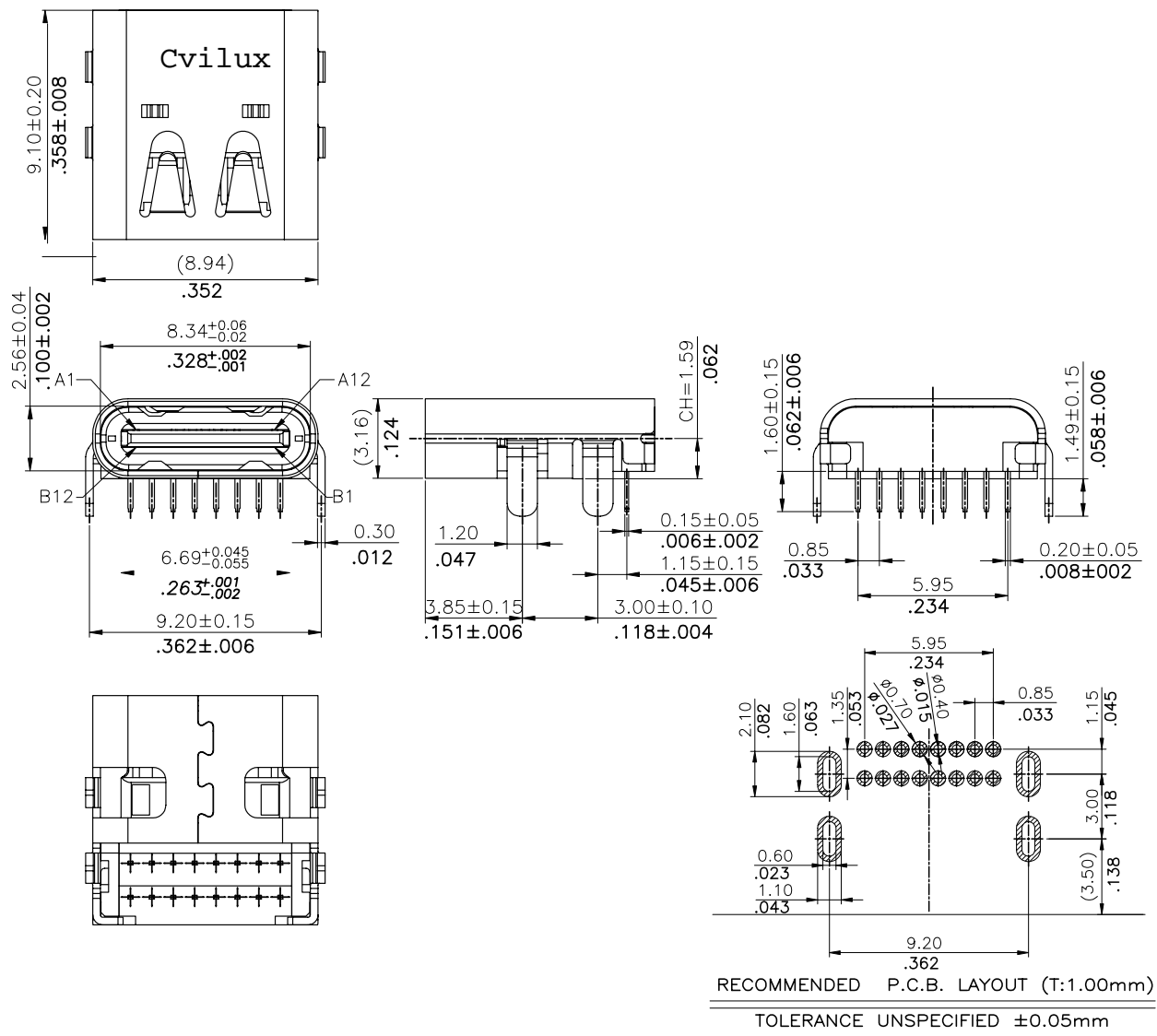

Ordering Code	①	②	③	④	⑤	⑥	⑦	⑧	⑨	⑩
	CU32	16	S	A	S	B	L	R	004	-NH

- ① Series No.
- ② No. of Circuits
- ③ S = Socket
- ④ Plating Code :  
A=Selective Gold Flash over Nickel  
B=Selective 15μ" Gold flash over Nickel  
C=Selective 30μ" Gold flash over Nickel  
2=Gold Flash over Nickel
- ⑤ Shell Material & Plating :  
S = Stainless Steel
- ⑥ Contact Material : B= Copper Alloy
- ⑦ Insulator Material & Color Option  
L=LCP Black
- ⑧ Packing : R =Tape & Reel
- ⑨ 004= With Logo 006= Without Logo
- ⑩ NH = For Lead Free soldering process and Halogen-Free

CU I/O CONNECTORS



**CU32 Series USB2.0 Type C Female SMT Type Connectors**

- ⊙ Top Mount SMT Type
- ⊙ High temperature plastic insulator
- ⊙ Contact current rating : 3 Amperes max
- ⊙ Dielectric strength:100V AC.
- ⊙ Durability cycles:10000 cycles

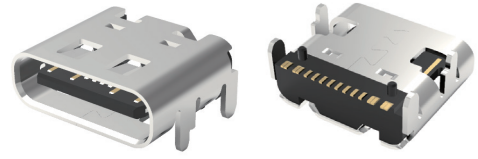

**RoHS** Compliant

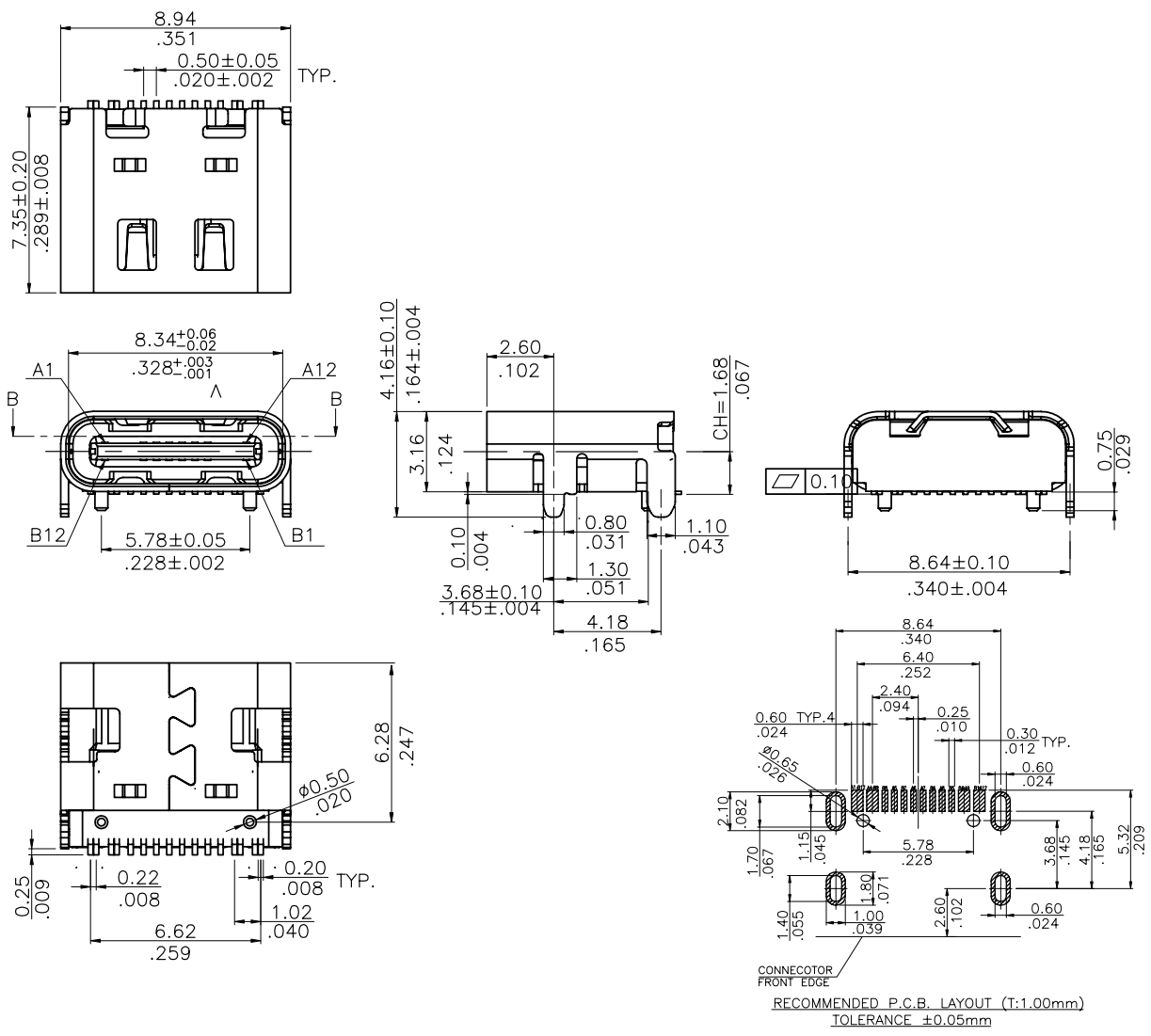

**Ordering Code**

①	②	③	④	⑤	⑥	⑦	⑧	⑨	⑩
<b>CU32</b>	<b>16</b>	<b>S</b>	<b>A</b>	<b>S</b>	<b>D</b>	<b>L</b>	<b>R</b>	<b>009</b>	<b>NH</b>

- ① Series No.
- ② No. of Circuits
- ③ S = Socket
- ④ Plating Code :  
A= Selective Gold Flash over Nickel  
2= Gold Flash over Nickel
- ⑤ Shell Material & Plating :  
S = Stainless steel
- ⑥ Contact Material : D= Copper Alloy
- ⑦ Insulator Material & Color Option : L=LCP Black
- ⑧ Packing : R =Tape & Reel
- ⑨ 009= With Logo 010= Without Logo
- ⑩ NH = For Lead Free soldering process and Halogen-Free

**CU32 Series USB2.0 Type C Female SMT Type Connectors**

- ⊙ Top Mount SMT Type
- ⊙ High temperature plastic insulator
- ⊙ Contact current rating : 5 Amperes max
- ⊙ Dielectric strength:100V AC.
- ⊙ Durability cycles:10000 cycles

**NEW**



RoHS Compliant

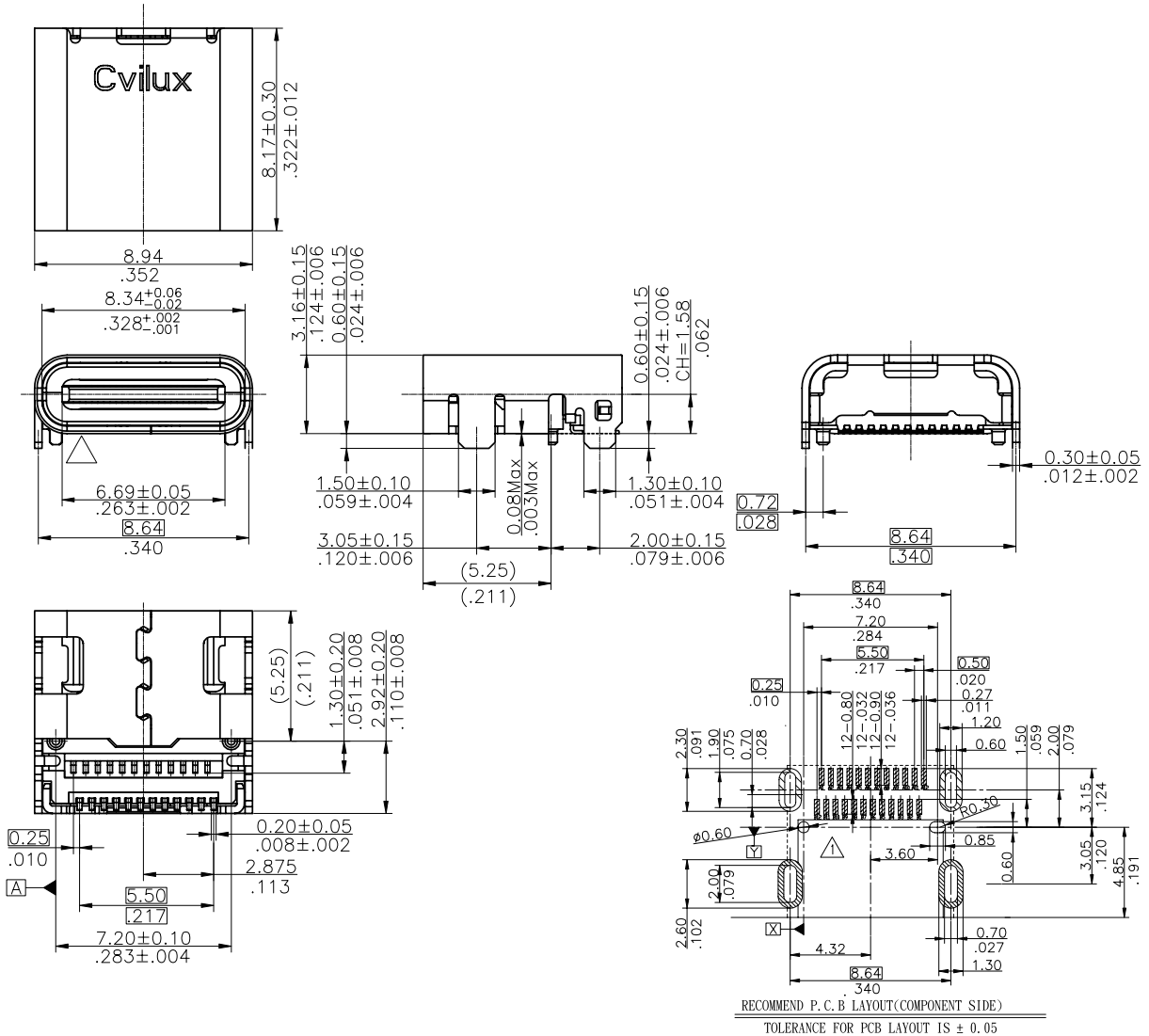

**Ordering Code**

① ② ③ ④ ⑤ ⑥ ⑦ ⑧ ⑨ ⑩  
**CU32 24 S A S B L R 007 - NH**

- ① Series No.
- ② No. of Circuits
- ③ S = Socket
- ④ Plating Code:  
 A=Selective Gold Flash over Nickel  
 B=Selective 15μ" Gold flash over Nickel  
 C=Selective 30μ" Gold flash over Nickel
- ⑤ Shell Material & Plating :  
 S = Stainless Steel
- ⑥ Contact Material : B= Copper Alloy
- ⑦ Insulator Material & Color Option : L=LCP Black
- ⑧ Packing : R =Tape & Reel
- ⑨ 007= With Logo 011= Without Logo
- ⑩ NH = For Lead Free soldering process and Halogen-Free

**CU32 Series USB2.0 Type C Female SMT Type Connectors**

- ⊙ Top Mount DIP + SMT Type
- ⊙ High temperature plastic insulator
- ⊙ Contact current rating : 3 Amperes max
- ⊙ Dielectric strength:100V AC.
- ⊙ Durability cycles:10000 cycles

**NEW**

RoHS Compliant

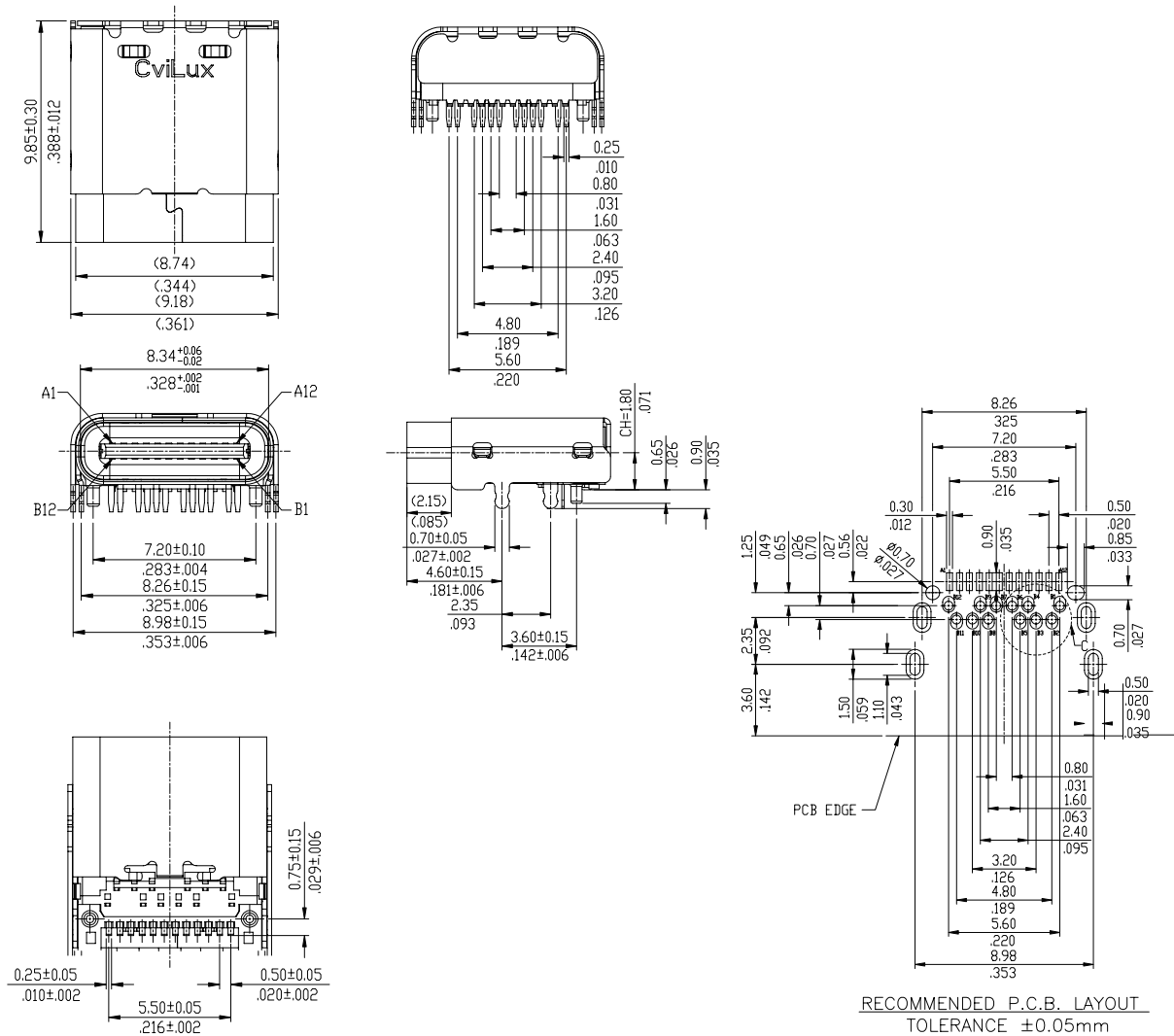
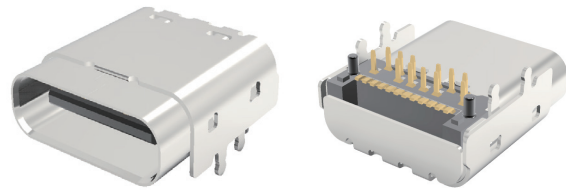

**Ordering Code**

① ② ③ ④ ⑤ ⑥ ⑦ ⑧ ⑨ ⑩  
**CU32 24 S A S B L R 008 - NH**

- ① Series No.
- ② No. of Circuits
- ③ S = Socket
- ④ Plating Code:  
 A=Selective Gold Flash over Nickel  
 B=Selective 15μ" Gold flash over Nickel  
 C=Selective 30μ" Gold flash over Nickel
- ⑤ Shell Material & Plating :  
 S = Stainless Steel
- ⑥ Contact Material : B= Copper Alloy
- ⑦ Insulator Material & Color Option : L=LCP Black
- ⑧ Packing : R =Tape & Reel
- ⑨ Other Option : 008
- ⑩ NH = For Lead Free soldering process and Halogen-Free

CU

I/O CONNECTORS

CU33 Series USB2.0 Type C Female Vertical Type Connectors

- ⊙ Vertical SMT Type
- ⊙ High temperature plastic insulator
- ⊙ Contact current rating : 3 Amperes max
- ⊙ Dielectric strength:100V AC.
- ⊙ Durability cycles:10000 cycles

**NEW**



RoHS Compliant

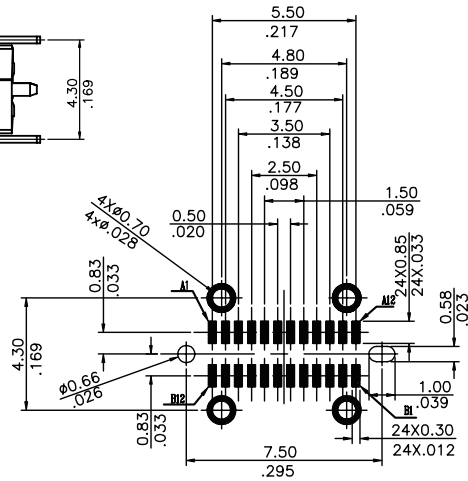
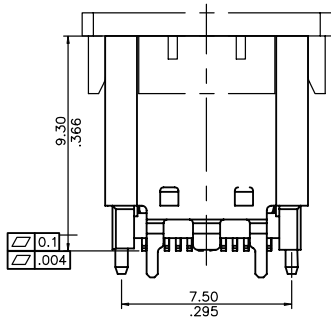
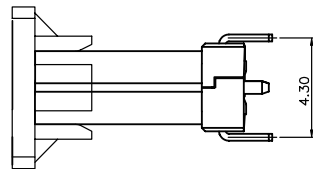
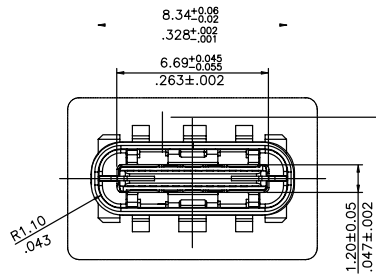
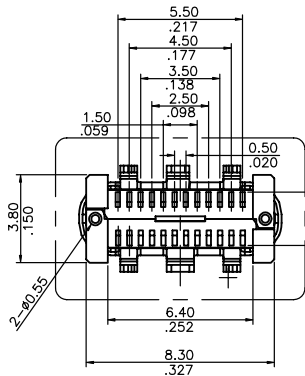
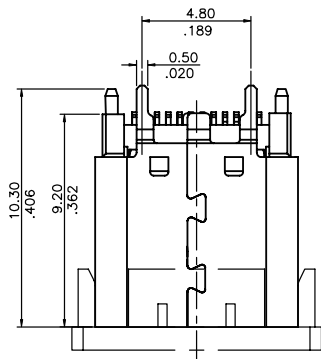

RECOMMENDED P.C.B. LAYOUT (T:1.00mm)  
TOLERANCE UNSPECIFIED ±0.05mm

Ordering Code

① ② ③ ④ ⑤ ⑥ ⑦ ⑧ ⑨ ⑩  
**CU33 24 S A S D L R 004 - LF**

- ① Series No.
- ② No. of Circuits
- ③ S = Socket
- ④ Plating Code :  
 A=Selective Gold Flash over Nickel  
 B=Selective 15µ" Gold flash over Nickel  
 C=Selective 30µ" Gold flash over Nickel
- ⑤ Shell Material & Plating :  
 S = Stainless steel
- ⑥ Contact Material : = Copper Alloy
- ⑦ Insulator Material & Color Option : L=LCP Black
- ⑧ Packing : R =Tape & Reel
- ⑨ Other Option : 004
- ⑩ LF = For Lead Free Soldering process



**CU33 Series USB2.0 Type C Female Vertical Type Connectors**

- ⊙ Vertical DIP Type
- ⊙ High temperature plastic insulator
- ⊙ Contact current rating : 5 Amperes max
- ⊙ Dielectric strength:100V AC.
- ⊙ Durability cycles:10000 cycles

**NEW**

RoHS Compliant

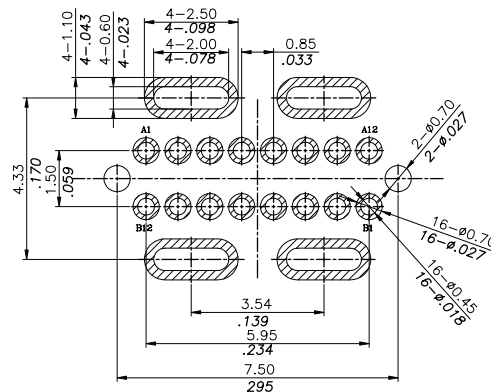
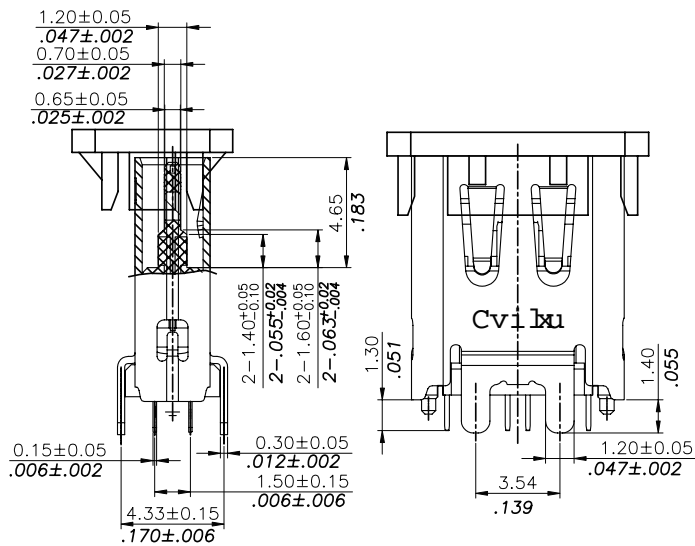
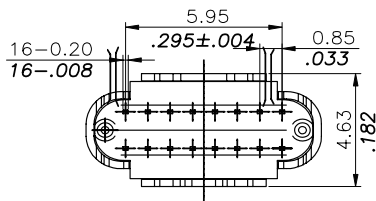
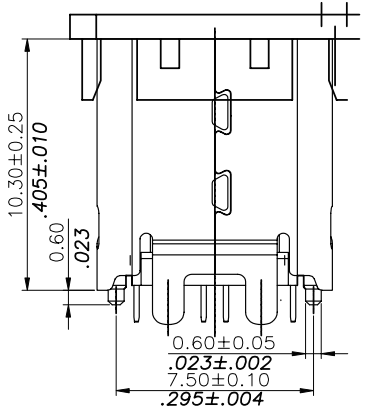
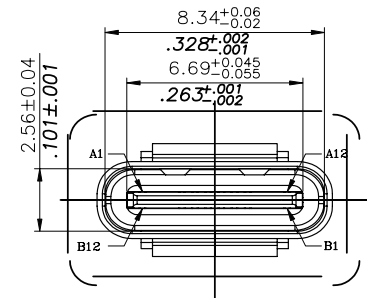
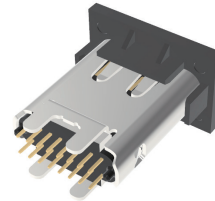

RECOMMENDED P.C.B. LAYOUT (T:1.00mm)  
TOLERANCE UNSPECIFIED ±0.05mm  
SCALE: 2:1

Ordering Code	①	②	③	④	⑤	⑥	⑦	⑧	⑨	⑩									
	<b>C</b>	<b>U</b>	<b>3</b>	<b>3</b>	<b>1</b>	<b>6</b>	<b>S</b>	<b>2</b>	<b>S</b>	<b>B</b>	<b>L</b>	<b>R</b>	<b>0</b>	<b>0</b>	<b>3</b>	<b>-</b>	<b>N</b>	<b>H</b>	
① Series No.																			
② No. of Circuits																			
③ S = Socket																			
④ Plating Code :																			
2= Gold Flash over Nickel																			
3=Selective 15µ" Gold flash over Nickel																			
4=Selective 30µ" Gold flash over Nickel																			
⑤ Shell Material & Plating :																			
S = Stainless Steel																			
⑥ Contact Material : B= Copper Alloy																			
⑦ Insulator Material & Color Option																			
L=LCP Black																			
⑧ Packing : R =Tape & Reel																			
⑨ Other Option : 003																			
⑩ NH = For Lead Free soldering process and Halogen-Free																			

CU33 Series USB Type C Plug SMT Type Connectors

- ⊙ Vertical SMT Type
- ⊙ High temperature plastic insulator
- ⊙ Contact current rating : 3 Amperes max
- ⊙ Dielectric strength:100V AC.
- ⊙ Durability cycles:10000 cycles

**NEW**

RoHS  Compliant

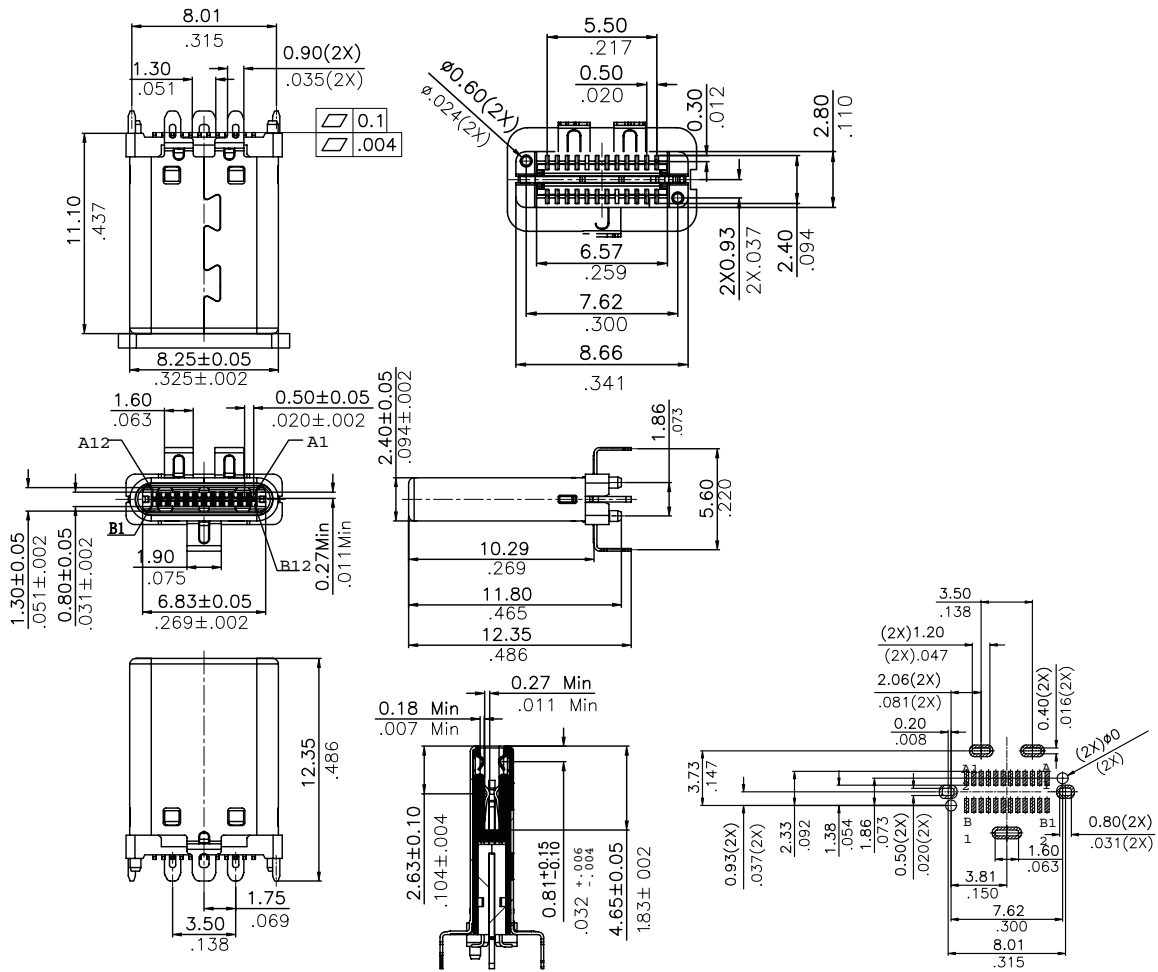
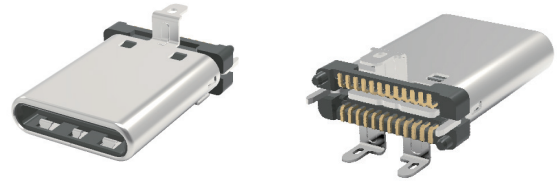

RECOMMENDED PCB LAYOUT(t=0.80±0.05)  
COMPONENT SIDE(GENERAL TOLERANCE:±0.05)

Ordering Code

① ② ③ ④ ⑤ ⑥ ⑦ ⑧ ⑨ ⑩  
**CU33 24 P A S D L R 001 - LF**

- ① Series No.
- ② No. of Circuits
- ③ P = Plug
- ④ Plating Code :  
A=Selective Gold Flash over Nickel
- ⑤ Shell Material & Plating  
S = Stainless Steel
- ⑥ Contact Material : D =Copper Alloy
- ⑦ Insulator Mateial & Color : L= LCP , Black
- ⑧ Packing : R = Tape & Reel
- ⑨ 001= Without Cover
- ⑩ LF = For Lead Free Soldering process

**CU34 Series USB2.0 Type C Female SMT Type Connectors**

- ⊙ Heightened SMT Type
- ⊙ High temperature plastic insulator
- ⊙ Contact current rating : 3 Amperes max
- ⊙ Dielectric strength:100V AC.
- ⊙ Durability cycles:10000 cycles

**NEW**

RoHS Compliant

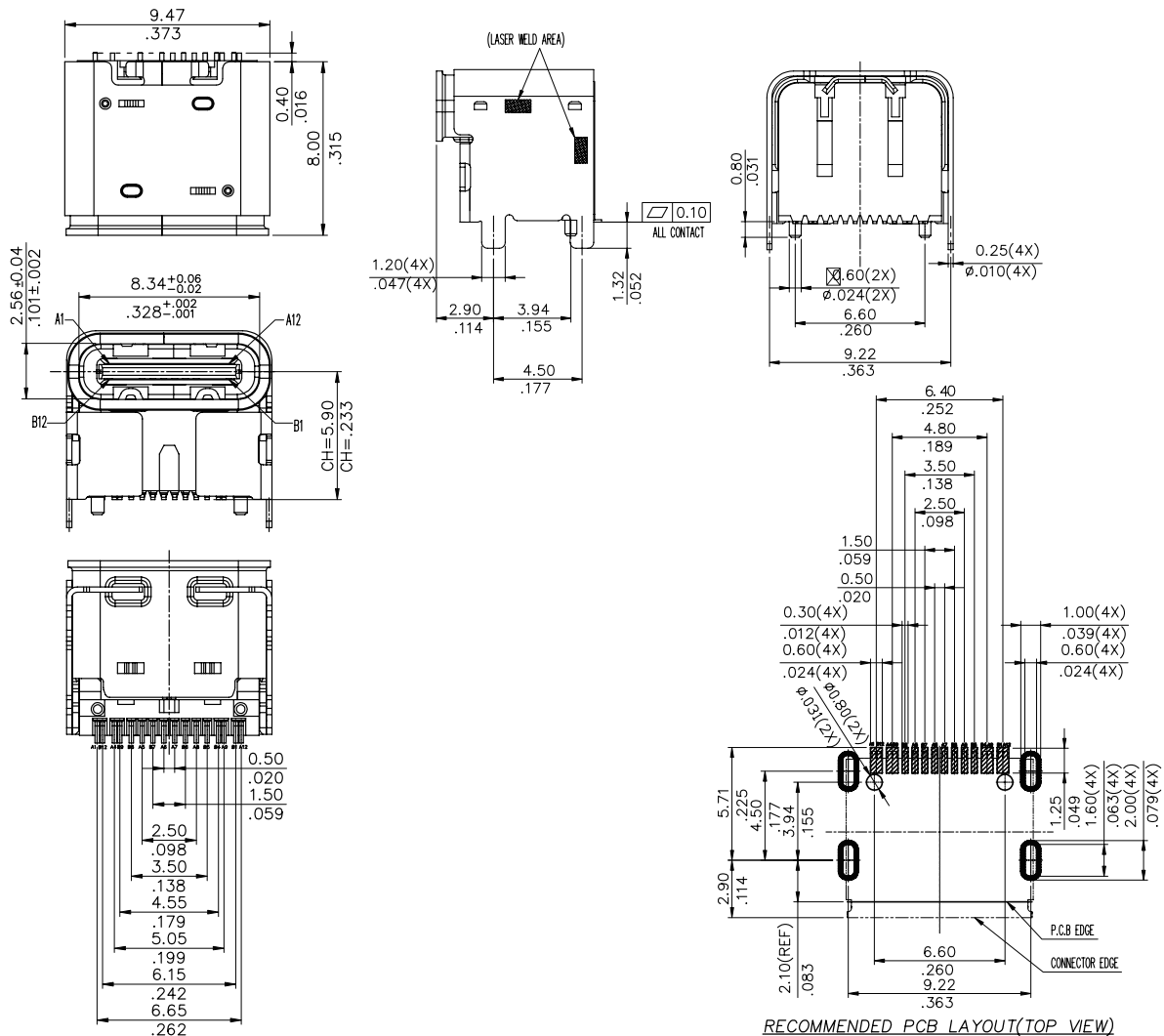

<b>Ordering Code</b>	①	②	③	④	⑤	⑥	⑦	⑧	⑨	⑩
	<b>CU34</b>	<b>16</b>	<b>S</b>	<b>2</b>	<b>S</b>	<b>A</b>	<b>L</b>	<b>R</b>	<b>001</b>	<b>-NH</b>

① Series No.	⑥ Contact Material : A= Copper Alloy
② No. of Circuits	⑦ Insulator Material & Color Option : L=LCP Black
③ S = Socket	⑧ Packing : R =Tape & Reel
④ Plating Code : 2= Gold Flash over Nickel	⑨ Other Option : 001
⑤ Shell Material & Plating : S = Stainless Steel	⑩ NH = For Lead Free soldering process and Halogen-Free

CU  
I/O CONNECTORS

**CU35 Series USB2.0 Type C Female Connectors**

- Ⓞ Side Plug DIP Type
- Ⓞ High temperature plastic insulator
- Ⓞ Contact current rating : 5 Amperes max
- Ⓞ Dielectric strength:100V AC.
- Ⓞ Durability cycles:10000 cycles



RoHS Compliant

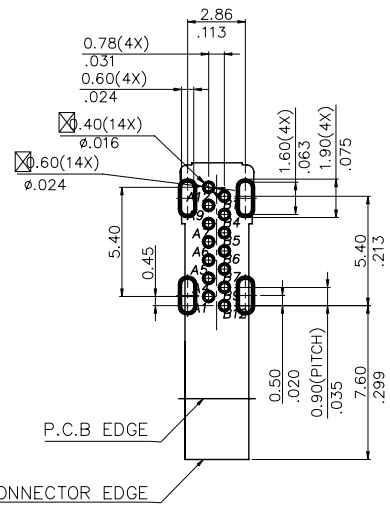
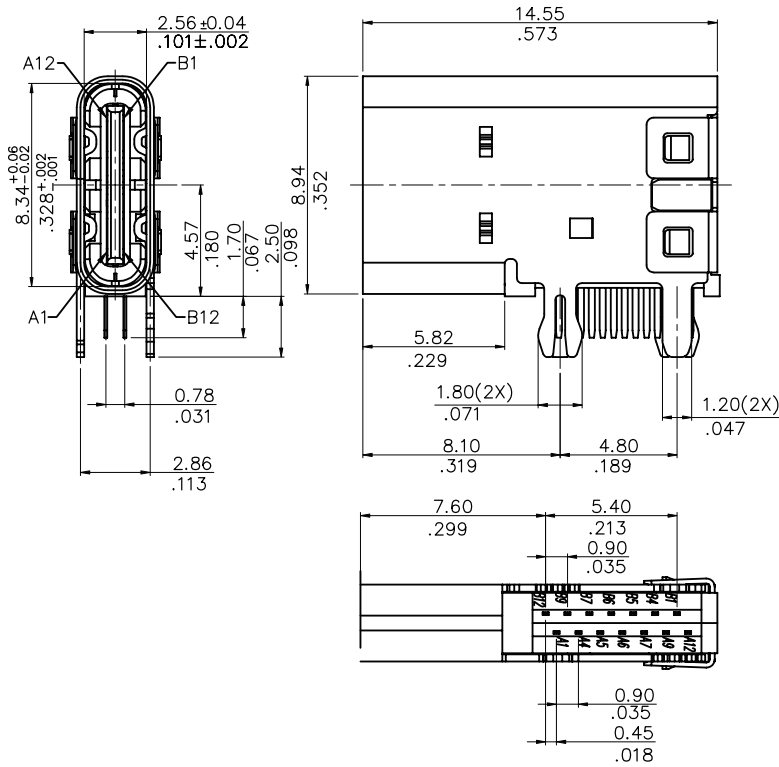
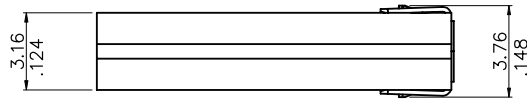

RECOMMENDED PCB LAYOUT(TOP VIEW)  
THICKNESS 1.6±0.10MM; DEFAULT TOLERANCE: ±0.05

**Ordering Code**

① ② ③ ④ ⑤ ⑥ ⑦ ⑧ ⑨ ⑩  
**CU35 14 S 2 S A L A 001 - NH**

- ① Series No.
- ② No. of Circuits
- ③ S = Socket
- ④ Plating Code :  
A= Selective Gold Flash over Nickel  
2= Gold Flash over Nickel
- ⑤ Shell Material & Plating :  
S = Stainless Steel
- ⑥ Contact Material : A= Copper Alloy
- ⑦ Insulator Material & Color Option  
L=LCP Black
- ⑧ Packing : A = Tray
- ⑨ Other Option : 001
- ⑩ NH = For Lead Free soldering process and Halogen-Free



# CU39 Series USB2.0 Type C Female Connectors

- ⊙ Top Monut SMT Type
- ⊙ IP 67 waterproof
- ⊙ High temperature plastic insulator
- ⊙ Contact current rating : 3 Amperes max
- ⊙ Dielectric strength:100V AC.
- ⊙ Durability cycles:10000 cycles

**NEW**



RoHS Compliant

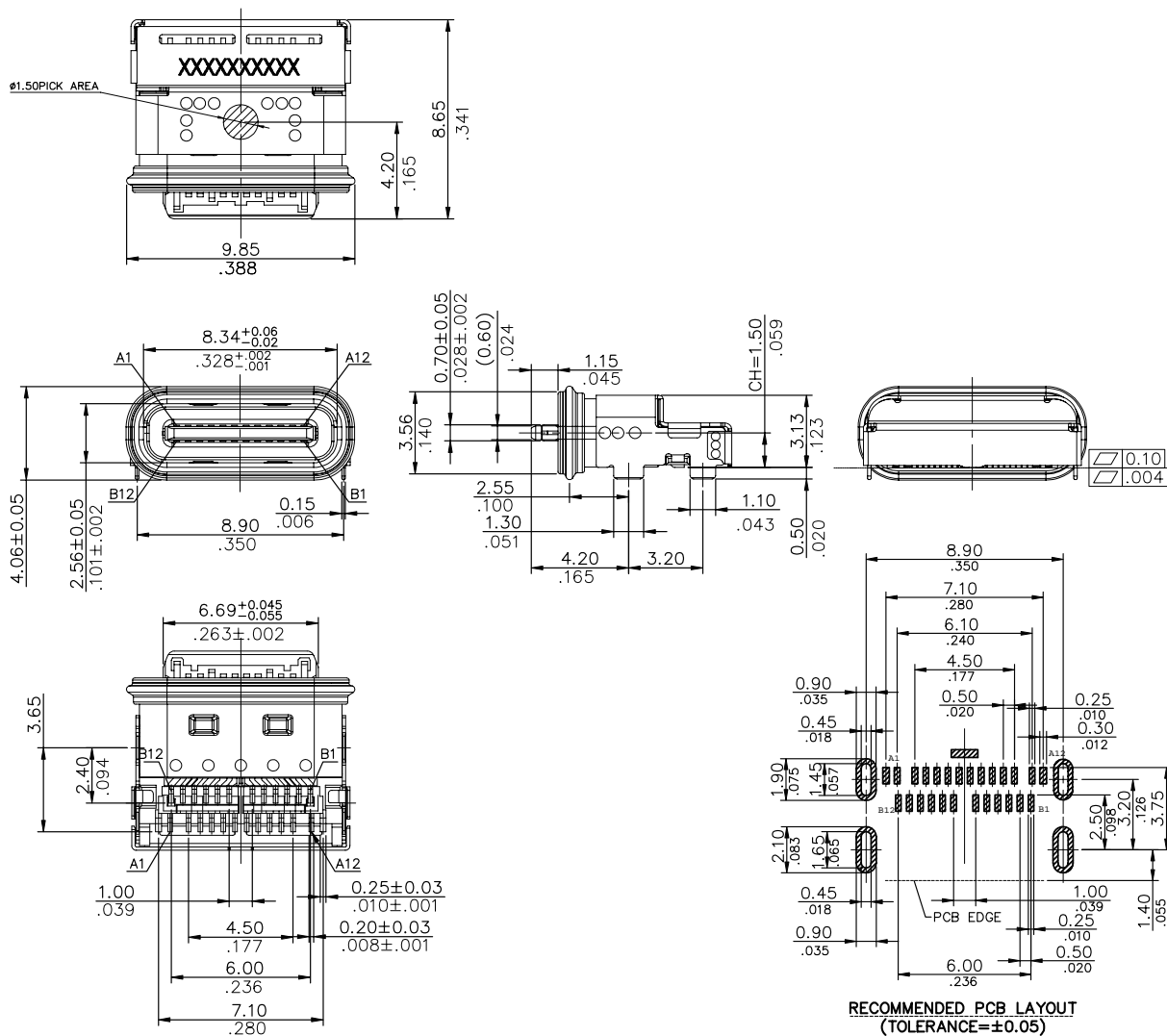

Ordering Code	①	②	③	④	⑤	⑥	⑦	⑧	⑨	⑩
	CU39	24	S	C	S	A	D	R	004	LF

① Series No.  
 ② No. of Circuits  
 ③ S = Socket  
 ④ Plating Code :  
 C= Selective 30μ" Gold flash over Nickel  
 ⑤ Shell Material & Plating :  
 S = Stainless steel  
 ⑥ Contact Material : A= Copper Alloy  
 ⑦ Insulator Material & Color Option  
 D = LCP Black  
 ⑧ Packing : R =Tape & Reel  
 ⑨ Other Option : 004  
 ⑩ LF = For Lead Free Soldering process

CU I/O CONNECTORS

**CU39 Series USB2.0 Type C Female Connectors**

- ⊙ Middle Mount DIP + SMT Type
- ⊙ IP 67 waterproof
- ⊙ High temperature plastic insulator
- ⊙ Contact current rating : 5 Amperes max
- ⊙ Dielectric strength:100V AC.
- ⊙ Durability cycles:10000 cycles

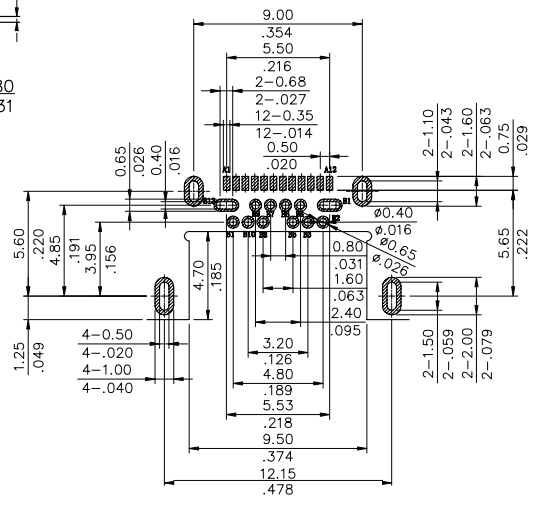
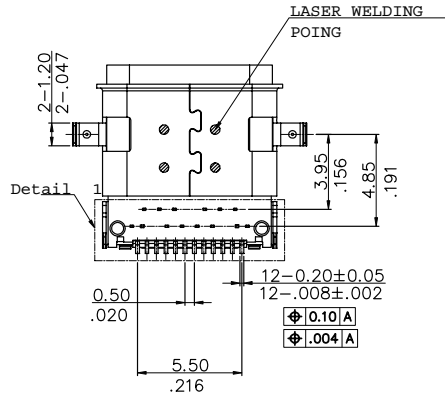
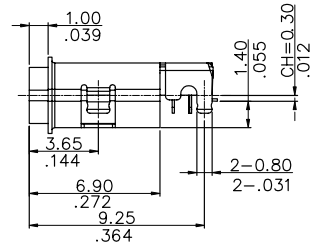
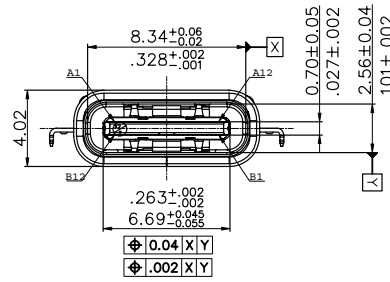
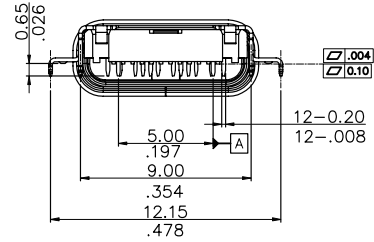
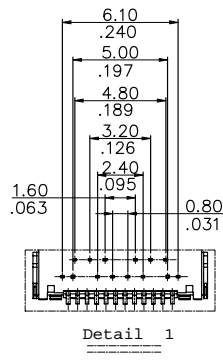
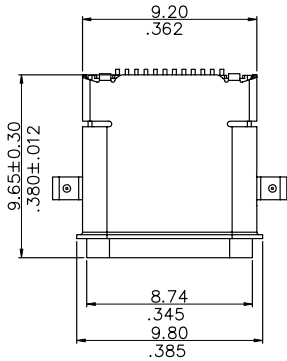
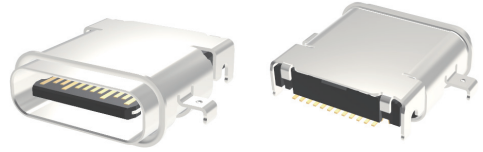

RECOMMENDED P.C.B LAYOUT(Both sides are sample)  
olerance: ±0.05, Thickness=0.60mm

**Ordering Code**

①	②	③	④	⑤	⑥	⑦	⑧	⑨	⑩
CU39	24	S	F	S	F	D	R	003	LF

- ① Series No.
- ② No. of Circuits
- ③ S = Socket
- ④ Plating Code :  
F = Selective Gold flash over Nickel
- ⑤ Shell Material & Plating : S = Stainless steel
- ⑥ Contact Material : F= Copper Alloy
- ⑦ Insulator Material & Color Option: D= High temperature Black
- ⑧ Packing : R=Tape & Reel
- ⑨ 003= Waterproof Type (IP67)
- ⑩ LF = For Lead Free Soldering process

CU

I/O CONNECTORS

# CU39 Series USB2.0 Type C Female Connectors

- ⊙ Middle Monut SMT Type
- ⊙ IP 67 waterproof
- ⊙ High temperature plastic insulator
- ⊙ Contact current rating : 5 Amperes max
- ⊙ Dielectric strength:100V AC.
- ⊙ Durability cycles:10000 cycles

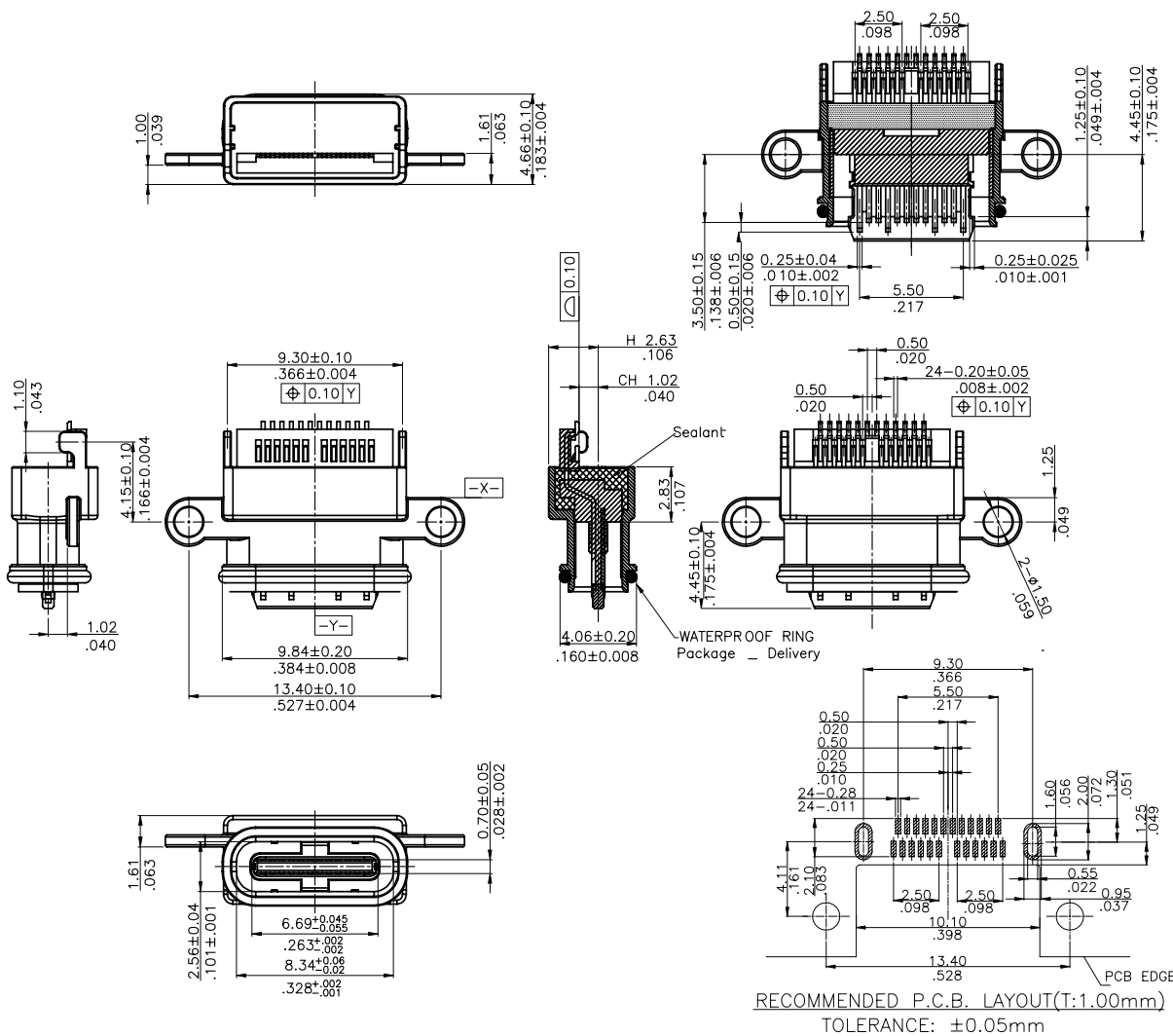
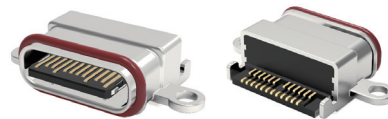

Ordering Code	①	②	③	④	⑤	⑥	⑦	⑧	⑨	⑩
	CU39	24	S	A	Z	B	N	R	001	-NH
① Series No.										
② No. of Circuits										
③ S = Socket										
④ Plating Code :										
A=Selective Gold Flash over Nickel										
B=Selective 15µ" Gold flash over Nickel										
C=Selective 30µ" Gold flash over Nickel										
⑤ Shell Material & Plating :										
Z = Kirsite										
⑥ Contact Material : B= Copper Alloy										
⑦ Insulator Material & Color Option										
N= PA4T Black										
⑧ Packing : R =Tape & Reel										
⑨ Other Option : 001= IP-X7										
007 =IP-X8										
⑩ NH = For Lead Free soldering process and Halogen-Free										

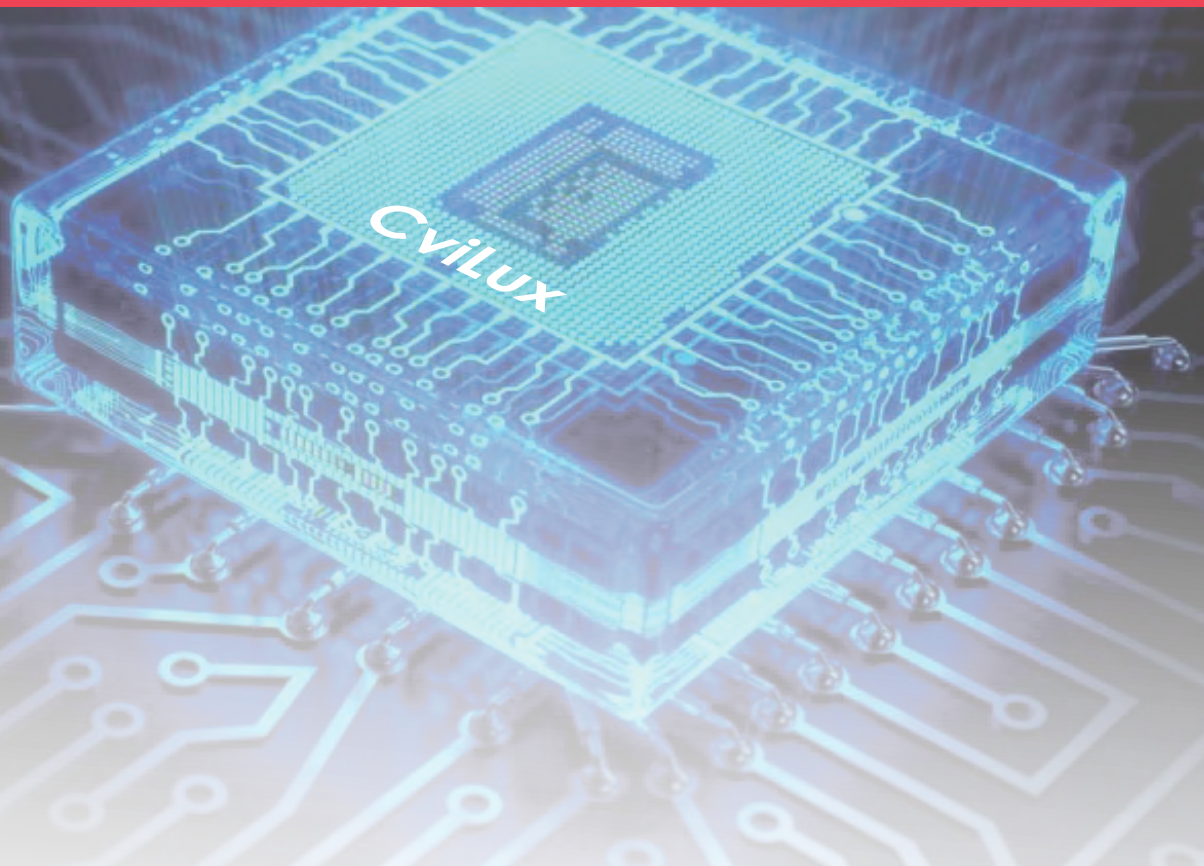

## **CVILUX PATENT, CERTIFICATE, AWARD**

CviLux R&D strength means maximizing our patents, awards and international standard of QC and certificates. We challenge our worldwide granted and pending patents listed as follows (- Oct., 2021) :

- Taiwan : 157 patents granted and pending
- China : 116 patents granted and pending
- USA : 10 patents granted and pending
- Japan : 3 patents granted and pending



CviLux Technology  
(Suzhou) Co., Ltd.



Anhui CviLux Technology  
Co., Ltd.



CviLux Lao Co., Ltd.



## Marketing Site

CviLux Corporation  
 CviLux Technology (Shenzhen) Corporation  
 CviLux USA Corporation  
 CviLux Opro9 Europe B.V.  
 CviLux SDN BHD  
 CviLux JAPAN Office  
 CviLux KOREA Corporation  
 CviLux QINGDAO Office  
 CviLux XIAMEN Office  
 Allsor Technology Corporation  
 Allsor Electronics Co., Ltd.  
 CviCloud Corporation  
 CviCloud (SZ) Limited

## Factory Site

Taiwan  
 CviLux Corporation  
 South China  
 CviLux Electronics (Dongguan)Co., Ltd.  
 Dongguan Qunhan Electronics Co., Ltd.  
 East China  
 CviLux Technology (Suzhou) Co., Ltd.  
 West China  
 CviLux Technology (Chongqing) Co., Ltd.  
 Central China  
 Anhui CviLux Technology Co., Ltd.  
 Lao  
 CviLux Lao Co., Ltd.

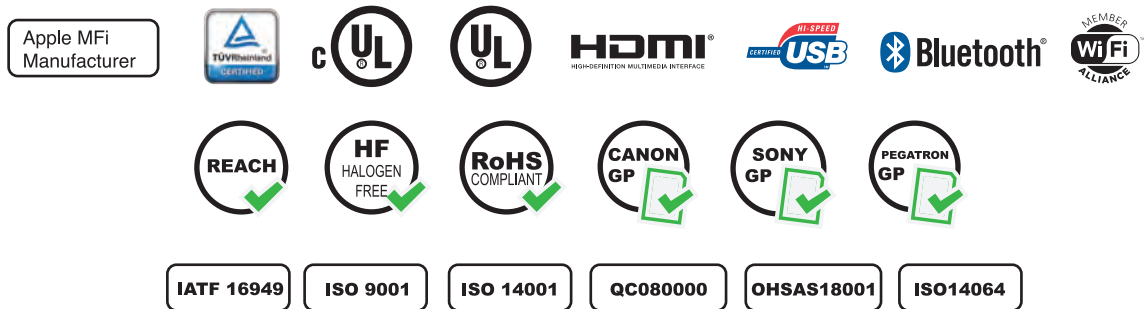

Taiwan      South China (Dongguan)      South China (Qunhan)      East China      West China      Central China      Lao

