

MATERIAL:

- 1.HOUSING: LCP, GLASS FIBER FILLED, BK
- 2.CONTACT: PHOSPHOR BRONZE (T=0.12mm)
- 3.GUARD PLATE:STAINLESS STEEL (T=0.10mm)
- 4.SHIELD: STAINLESS STEEL (T=0.30mm)

FINISH:

- CONTACT: GOLD PLATING ON CONTACT AREA,
MATTE TIN PLATING ON SOLDER TAILS,
NICKEL UNDERPLATING OVER ALL
- SHELL: NICKEL PLATING

Ordering Code:

CU18 24 S * H 1 M D 0 R0 -LF -HC
 ① ② ③ ④ ⑤ ⑥ ⑦ ⑧ ⑨ ⑩ ⑪ ⑫

- ① Series No.
- ② No. of Circuits
- ③ S=Socket
- ④ Plating option:
 A= 1u" gold plated on Contact area,
 Matte Tin plated on Solder tails,
 Nickel underplating over all
 B= 15u" gold plated on Contact area,
 Matte Tin plated on Solder tails,
 Nickel underplating over all
 C= 30u" gold plated on Contact area,
 Matte Tin plated on Solder tails,
 Nickel underplating over all
- ⑤ Contact tail style: H= Top mount Right Angle
- ⑥ Insulator Color: 1= Black
- ⑦ Contact Solder tail Style: M=SMT
- ⑧ Shell Type: D= DIP Type
- ⑨ Transmission speeds:
 0= For Gen1(Gold 15u")
 1= For Gen2(Gold 30u")
 2= For USB 2.0(Gold 1u")
- ⑩ Packing: R0= Tape & Reel
- ⑪ -LF=For Lead Free IR Reflow Process
- ⑫ -HC= For High Current

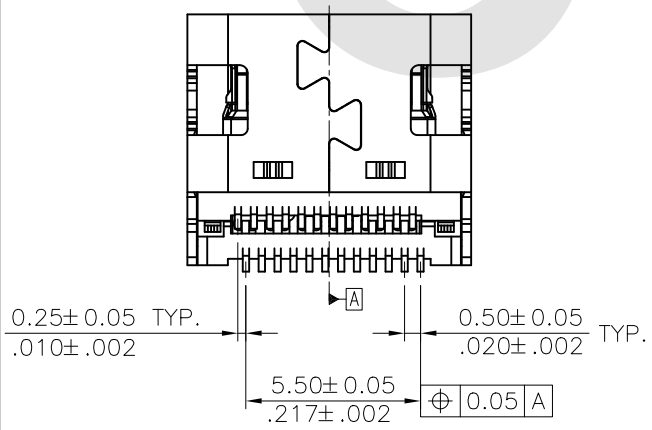
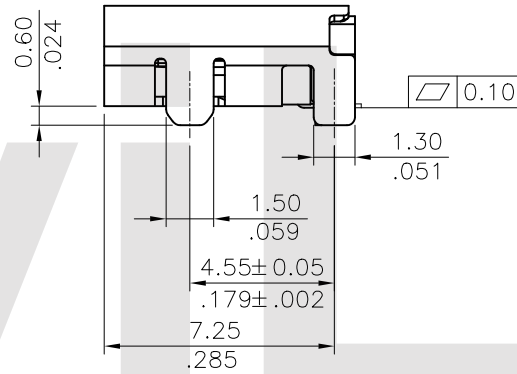
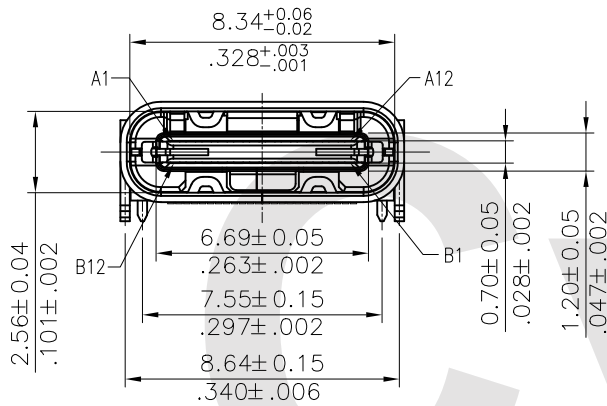

④					DATE	UNIT: mm / inch	TITLE: U.S.B TYPE C SOCKET SMT TOP MOUNT RIGHT ANGLE
③					DRAWN BY: Yan	5/15-17'	MATERIAL:
②					ENGINEER: Yan	5/15-17'	
①					CHECKED BY: Andy	5/15-17'	FINISH:
SYM	NAME	DATE	REVISIONS	APPROVED BY: Andy	5/15-17'		

CVILUX CORP
 2017.06.15
 ISSUED

Lead Free Process RoHS Compliant

瀚荃股份有限公司
CviLux Corporation

DRAWING NO.	CU1825SA	PART NO.	CU1824S*H1MD*R0-LF-HC
SCALE	4 / 1	SHEET	1 OF 3

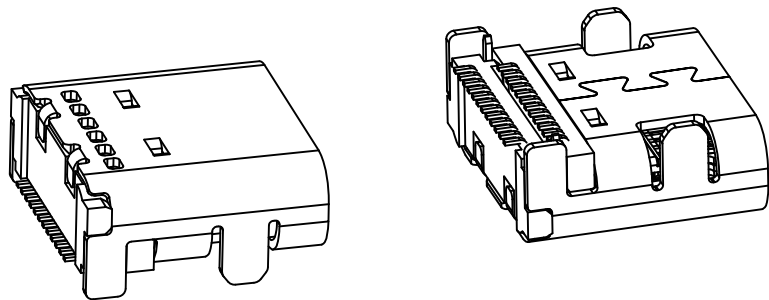

USB TYPE-C FULL-FEATURED RECEPTACLE INTERFACE PIN ASSIGNMENTS

PIN	Signal Name	Description	PIN	Signal Name	Description
A1	GND	Ground return	B12	GND	Ground return
A2	SSTXp1	Positive half of first SuperSpeed TX differential pair	B11	SSRXp1	Positive half of first SuperSpeed RX differential pair
A3	SSTXn1	Negative half of first SuperSpeed TX differential pair	B10	SSRXn1	Negative half of first SuperSpeed RX differential pair
A4	Vbus	Bus Power	B9	VBUS	Bus Power
A5	CC1	Configuration Channel	B8	SBU2	Sideband Use(SBU)
A6	Dp1	Positive half of the USB 2.0 differential pair-Position 1	B7	Dn2	Negative half of the USB 2.0 differential pair-Position 2
A7	Dn1	Negative half of the USB 2.0 differential pair-Position 1	B6	Dp2	Positive half of the USB 2.0 differential pair-Position 2
A8	SBU1	Sideband Use(SBU)	B5	CC2	Configuration Channel
A9	VBUS	Bus Power	B4	VBUS	Bus Power
A10	SSRXn2	Negative half of second SuperSpeed RX differential pair	B3	SSTXn2	Negative half of second SuperSpeed TX differential pair
A11	SSRXp2	Positive half of second SuperSpeed RX differential pair	B2	SSTXp2	Positive half of second SuperSpeed TX differential pair
A12	GND	Ground return	B1	GND	Ground return

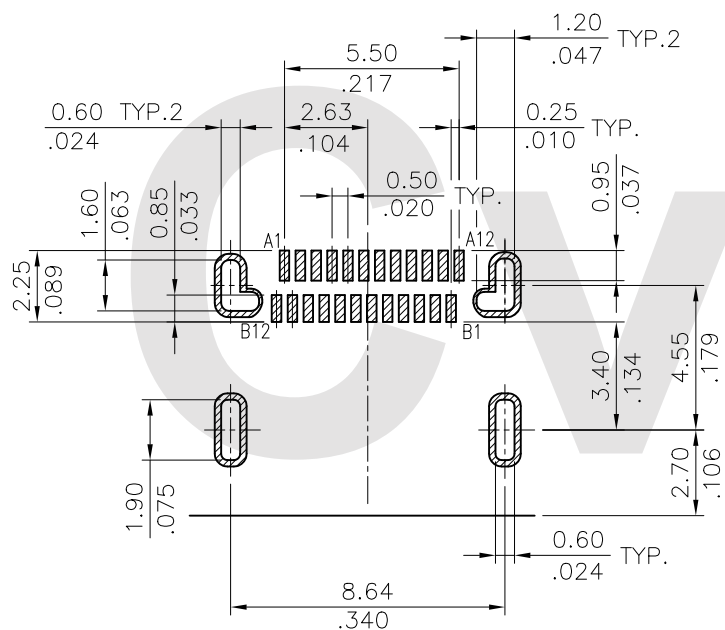

RECOMMENDED P.C.B. LAYOUT(T:1.00mm)
TOLERANCE: ± 0.05mm

Lead Free Process

RoHS Compliant

4					DATE	UNIT: mm / inch	TITLE: U.S.B TYPE C SOCKET SMT TOP MOUNT RIGHT ANGLE	 瀚荃股份有限公司 CviLux Corporation
3					DRAWN BY: Yan	TOLERANCE UNLESS OTHERWISE SPECIFIED	MATERIAL:	
2					ENGINEER: Yan	.X ± 0.25/.010 X' ± 4'	FINISH:	PART NO. CU1824S*H1MD*RO-LF-HC
1					CHECKED BY: Andy	.XX ± 0.20/.008 X' ± 2'		SCALE 4 / 1
SYM	NAME	DATE	REVISIONS		APPROVED BY: Andy	.XXX ± 0.10/.004 .XX ±		



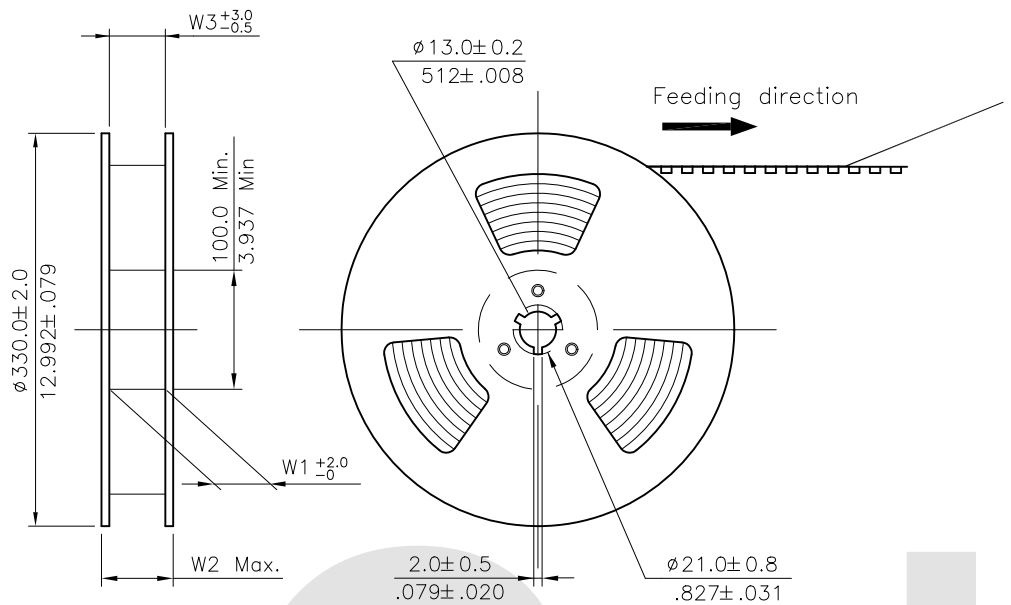

- NOTE :
- * Reel Material : HIPS
 - * Carrier Material : Clear, Conductive Polystyrene Alloy
 - * Cover Tape Material : Polyester
 - * Cover Tape Peel Strength : 0.1N – 1.3N
 - * Carrier camber is within 1mm in 250mm
 - * All dimensions meet EIA-481-B requirements.
 - * Quantity : 900 PCS/Reel

Dimension				Packing (Reel/Carton)
E	W1	W2	W3	
24.0(.945)	24.5(.965)	30.5(1.201)	24.5(.965)	10

CviLUX

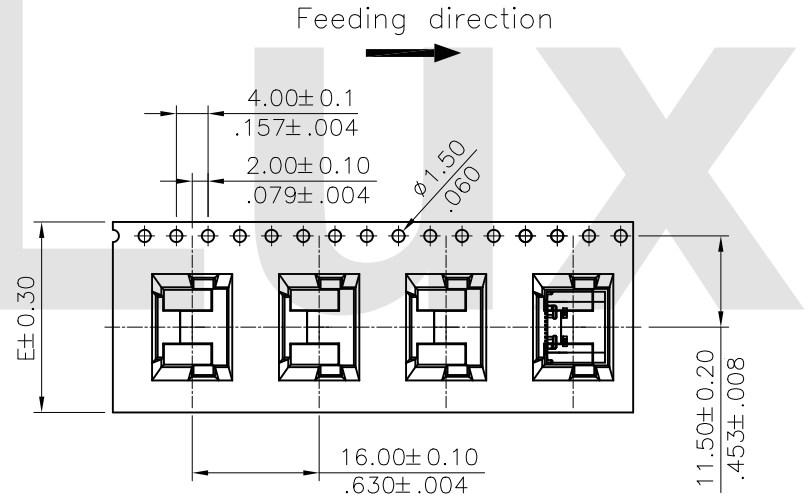
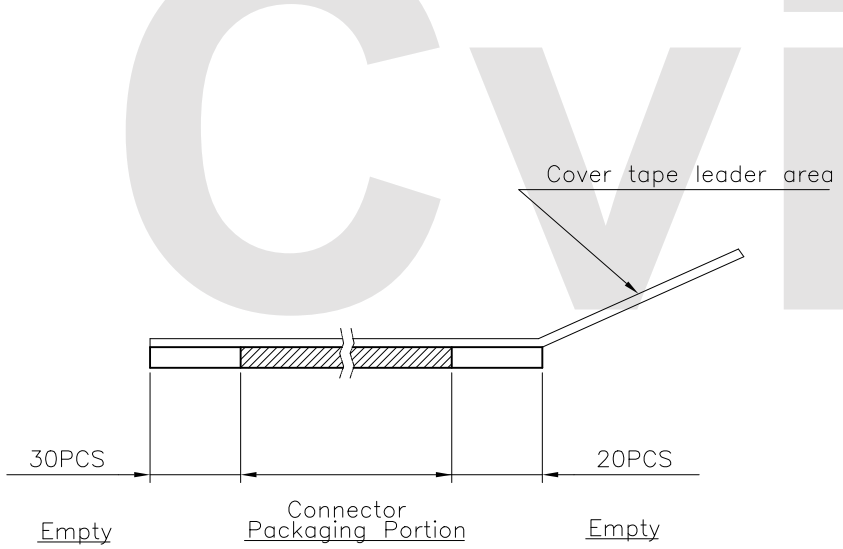

WIDTH : 24 mm Carrier

RoHS Compliant

4					DATE	UNIT: mm / inch	TITLE: U.S.B TYPE C SOCKET SMT TOP MOUNT RIGHT ANGLE	瀚荃股份有限公司 CviLux Corporation
3					DRAWN BY: Yan	TOLERANCE UNLESS OTHERWISE SPECIFIED	MATERIAL:	
2					ENGINEER: Yan	.X ± X' ± "	FINISH:	DRAWING NO. CU1825SA
1					CHECKED BY: Andy	.XX ± .X' ± "		PART NO. CU1824S*H1MD*RO-LF-HC
SYM	NAME	DATE	REVISIONS	APPROVED BY: Andy	5/15-17'	.XXX ± .XX' ± "	SCALE	SHEET 3 OF 3

CviLUX CORP
 2017.06.15
 ISSUED